

Skyline

Book Binding Machines & Supplies

Sales • Service • Repair

Professional Service – Fast Nationwide Shipping

1-866-455-9900

www.OnlineSkyline.com CustomerService@onlineskyline.com

IM8100 Inline System

User's Manual



This manual does not include all the contents about ES8000. Please refer to the user's manual given.

1. Identifying parts

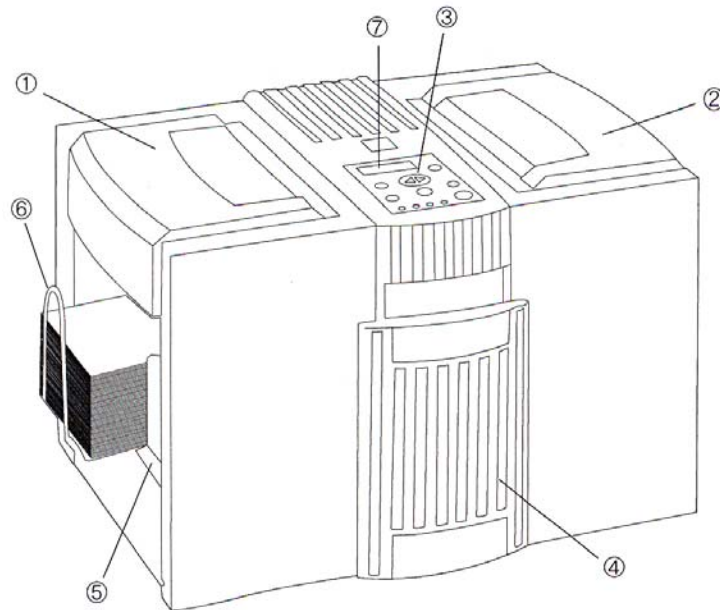

- ① Safety cover of feeding unit
- ② Safety cover of upper folding cassette
- ③ Control panel
- ④ Lower cassette cover
- ⑤ Paper tray
- ⑥ Feed assist hanger
- ⑦ Display panel

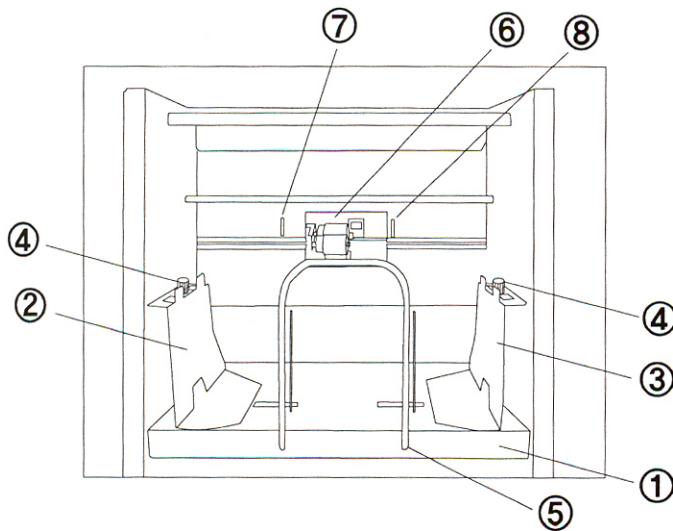

- ① Paper tray
- ② Feed guide (left)
- ③ Feed guide (right)
- ④ Feed guide knob
- ⑤ Feed assist hanger
- ⑥ Feed roller assembly
(Pick-up, feed, separate roller)
- ⑦ Control sensor for paper detection
- ⑧ Control sensor for tray height

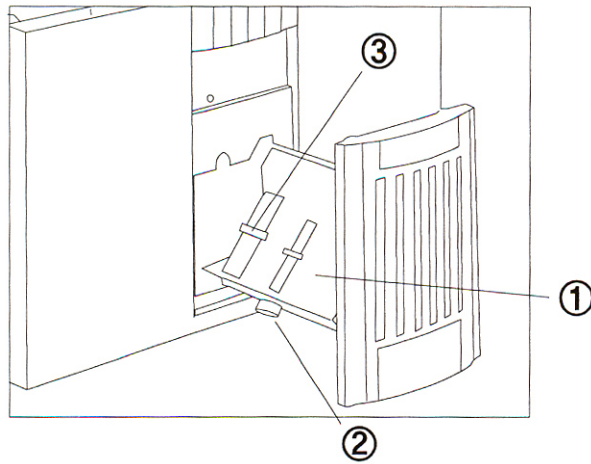

- ① Lower cassette
- ② Lower cassette
Stopper adjustment knob
- ③ Lower cassette stopper

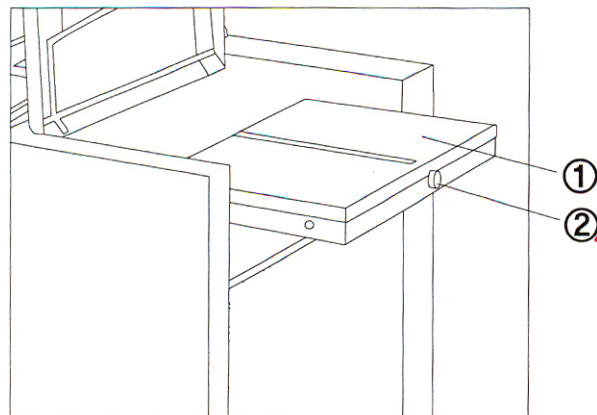

- ① Upper cassette
- ② Upper cassette stopper
adjustment knob

2. IM8100 Inline Parts

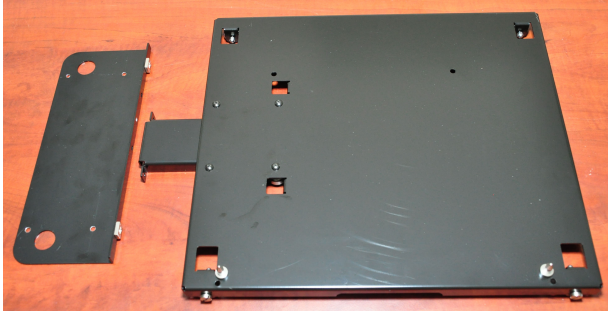

<HP Printer Only Slide Mount Base>



<Interface>



<Interface fixing screw>



<Interface Top Guide>

3. Control Panel



- On-line: When the pressure sealer is connected to the printer.
- Off-line: When the pressure sealer is not connected to the printer.
- Counter: Set counting at off-line mode.
Not available in on-line mode.
- Set: Stores the selected function.
- Thickness: Detects double feeds and stops the unit.
Not available in on-line mode
- Jam free: Removes paper jam in the folding cassette.
- Alarm: Indicates an error or a jam
- Start/Stop: Starts or stops operation.
- Display: Displays the unit's current status.

★ In order to use IM8100 as an Off-Line machine without the printer interface, please perform the following procedures to change the mode to an off-line mode. Make sure to remove "Interface and Interface Top Guide"

1. Press the "set/store" button for 3 seconds to change the setup mode.
2. Press the "set/store" button 3 times and the Online mode will be on display.
3. Press the select button (◀▶) to change the mode to an Off-line mode.
4. Press the "start/stop" button to accept the change and the machine will be ready.
5. ** Press and hold down Mode button to temporary switch the mode from an online to an offline mode. the machine will go back to On-Line mode after machine turn off.

★ Changing from an offline to an online mode by pressing the mode button is only supported when the setup mode is in an online mode (Step # 5).

4. Interface unit installation and printer connection

1> Place the IM8100 rear feet onto the circular cut outs on the bracket.

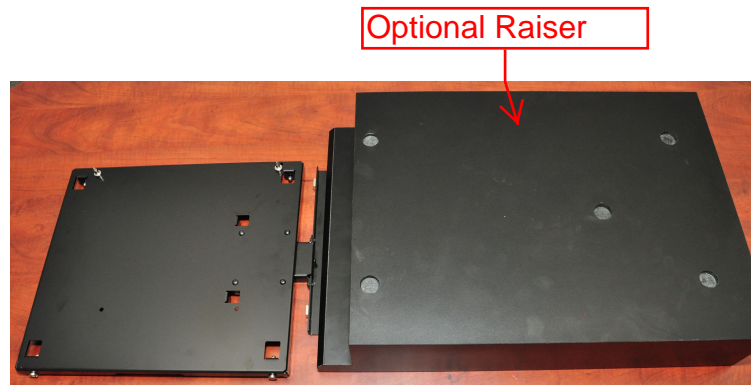
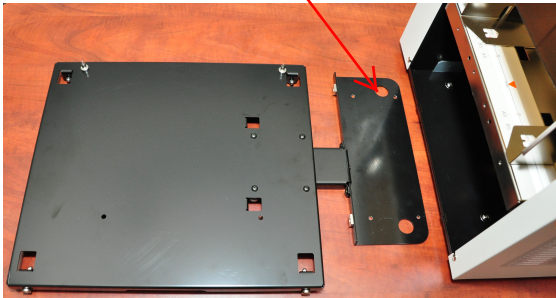

2> Turn on the power and set the unit in an offline mode by pressing on the mode button. Then open the safety cover of the feeding unit and the tray will go down.

3> Widen the paper guide as much as possible and tighten the green knob.



4> Place the Interface onto the tray and tighten the screw.



< Interface fixing screw >



< Interface >



5> Connect the cable inside the feeder to the interface.

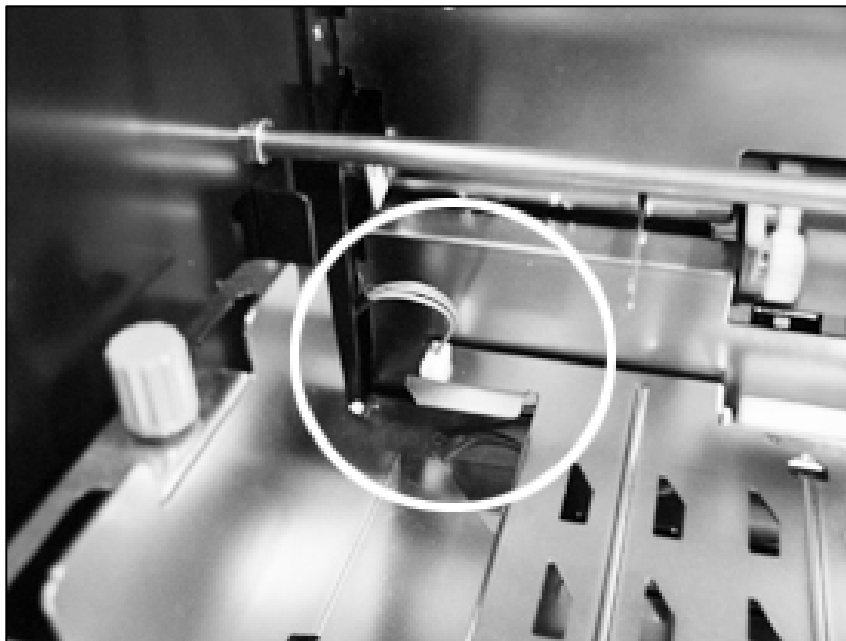

6> Change the mode to on-line and close the cover, which will make the tray to go down.

7> Open the cover and install the interface guide.

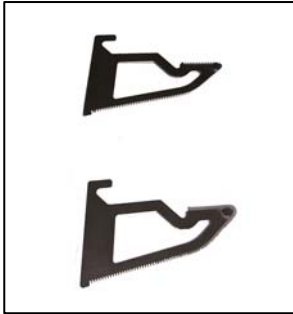

When installing the top guides like the picture, make sure they are completely attached to the shaft of the machine. Push the top guide towards the bottom shaft until they are clicked and are properly fixed to the shaft. Also make sure the sensors on the Left side of the rollers are picked up by the top guide magnets.

8> Adjust the Folding positions on upper/lower cassette according to the paper size

→ Please refer to the fold manual

9> Check whether the operation panel displays “ready online.”

10> Place the printer on the printer slide mount base. This picture below is showing with optional raiser



11> Connect the network printer cable to your network cable.

(Connect the USB cable from your computer directly to the printer if your printer is not in a network environment.)

Please **do not** use a parallel cable.

Tie the power cable and the cross cable and fix them to the surface of the product by using the clamp and the cable tie, like the picture below.

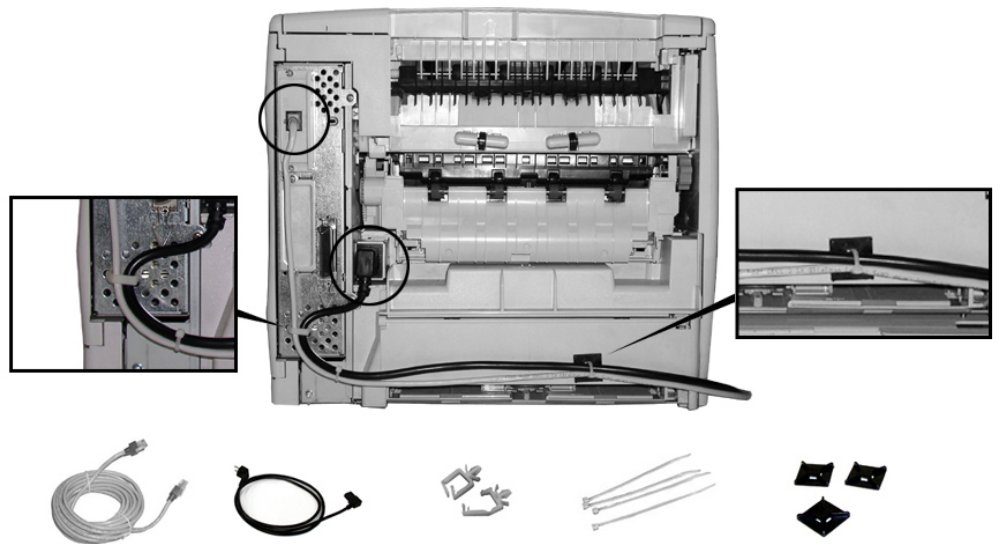

<Cross cable>< power cable><cable fixing clamp><cable tie> <mount base>

12> Load the paper to the printer and process a sample page, adjust side guide so that your papers exit from the printer just fall in between the two side guides. Test one page at a time until you get perfect landing.

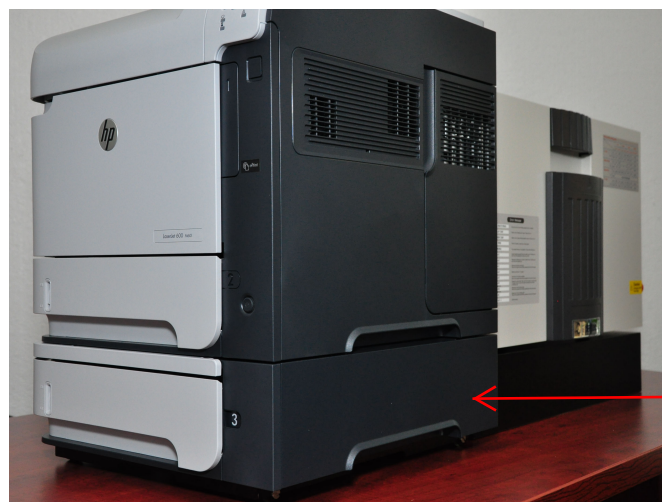

Optional feed tray

5. How to set the folding position.



- 1) Open the safety cover of the upper cassette and adjust the location of the stopper according to the folding position manual shown on the folding cassette



	93 99	118	140	149 150	187	198	238
<i>Fold Styles</i>							
<i>Paper Length</i>							
A4 (297mm)		99			198		149
Letter (279mm)		93			187		140
Legal (356mm)		118			238		150

2) Open the safety cover of the lower cassette and adjust the location of the stopper according to the folding position manual shown on the folding cassette.



Paper Length	Fold Styles		
	Z-fold	C-fold	Double-fold
70 74			
93 99 102	A4 (297)	99	99
120	LETTER (279)	93	93
	LEGAL (356)	120	120
		120	102

6. How to operate in an off-line mode.

- 1) Remove the Interface Top Guides, Disconnect the cable connected to the interface.
- 2) Change mode into an off-line mode and open the safety cover, then the tray will go down.
- 3) Unscrew the screws and remove the interface.
- 4) Load the paper onto the tray.
- 5) Adjust the tray Side Guide according to the width of the paper and fix the knob.
- 6) Check the Fold size setup on the upper/lower folding cassette.
- 7) Start your operation by run a few single sheet one at a time to make sure fold size are setup correctly.

7. How to remove paper-jam

(Refer to the manual 4-2)

- 1) Press the <stop/restart> button on the **printer** to stop printing.
- 2) Slide Printer away from the machine.
- 3) Open the cover of the feeding tray and remove the paper.
- 4) Press <start/stop> button of **the sealer** and return to "ready online" mode.
- 5) Close the cover and connect the printer.
- 6) Press the <stop/restart> button on the **printer** and start printing.
- 7) The jammed paper (already printed) still can be sealed by feeding it into the printer with non-printing function.

8. Before using the unit

Please Jog your Forms (papers) before loading to the Printer Feed tray. Make sure printer is align with pressure sealer machine. Print several single page for test run.

