



Skyline

Book Binding Machines & Supplies

Sales • Service • Repair

Professional Service – Fast Nationwide Shipping

1-866-455-9900

www.OnlineSkyline.com CustomerService@onlineskyline.com

ES2000 - INFEED TRAY PART CATALOGUE

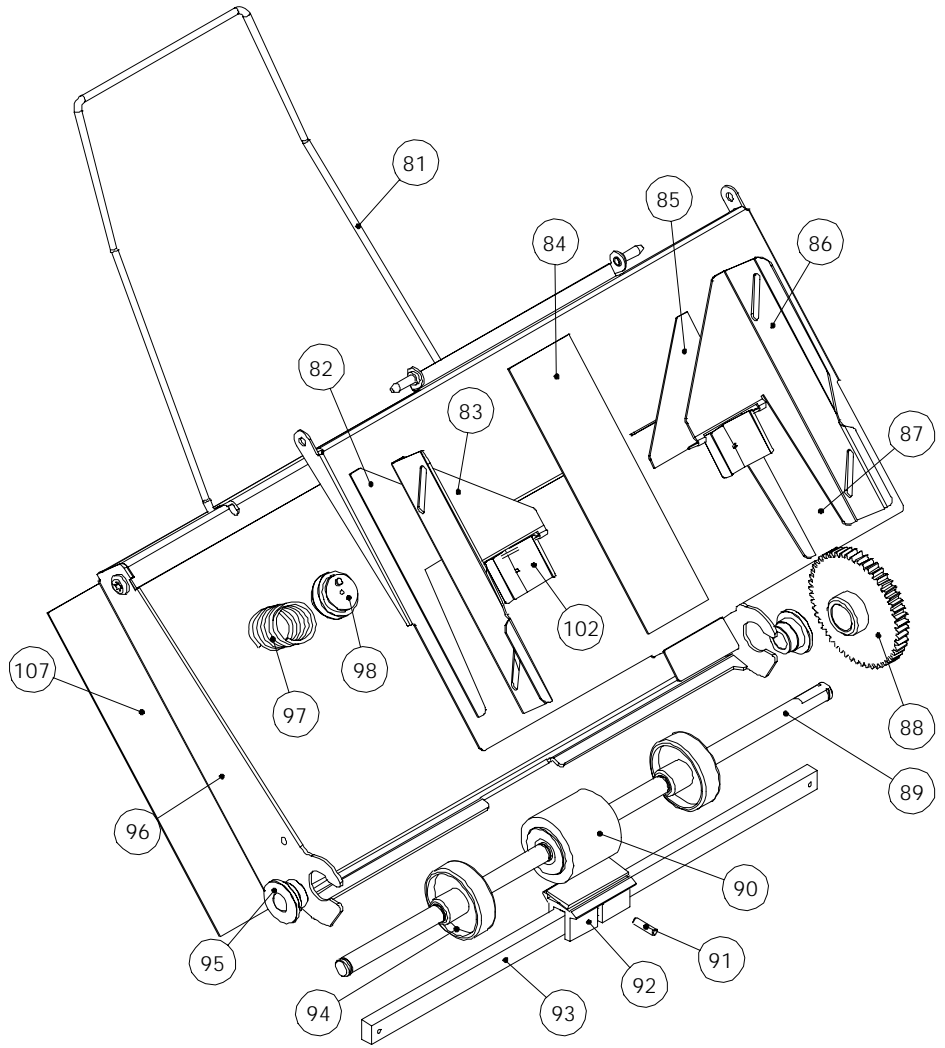

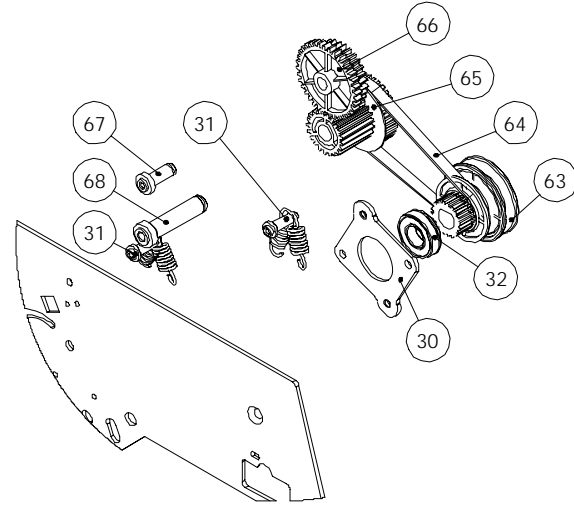
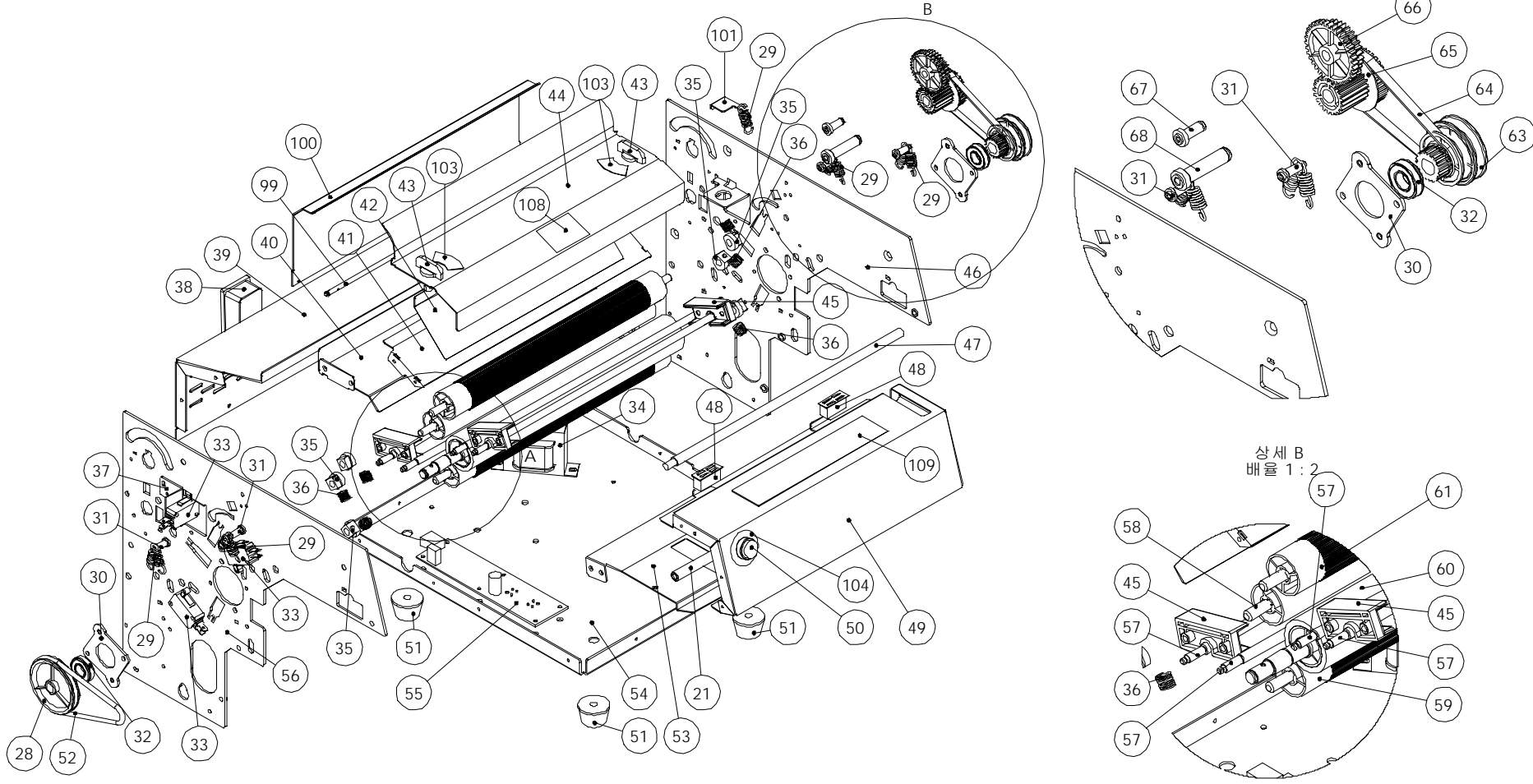

상세 B
배율 1:2

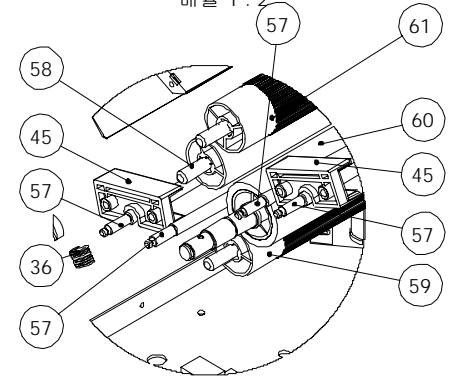

상세 A
배율 1:2

110



114



<MAIN BOARD : YH396-03V>

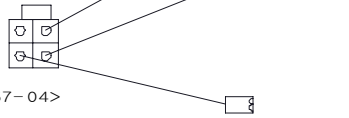

<AC MOTOR : 5557-04>

115

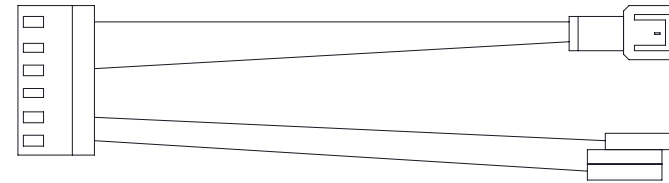

111



112



116

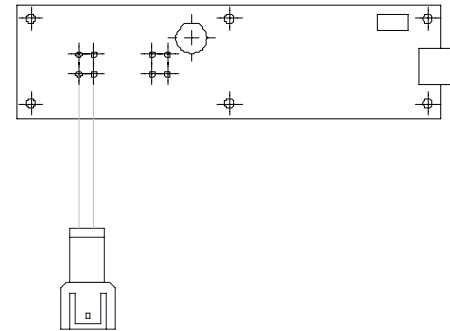

113

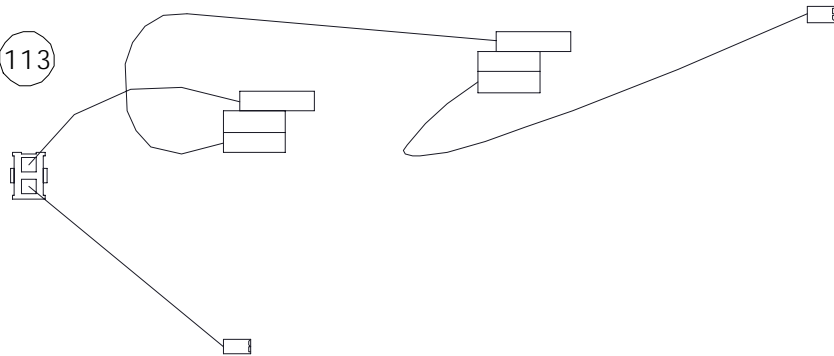

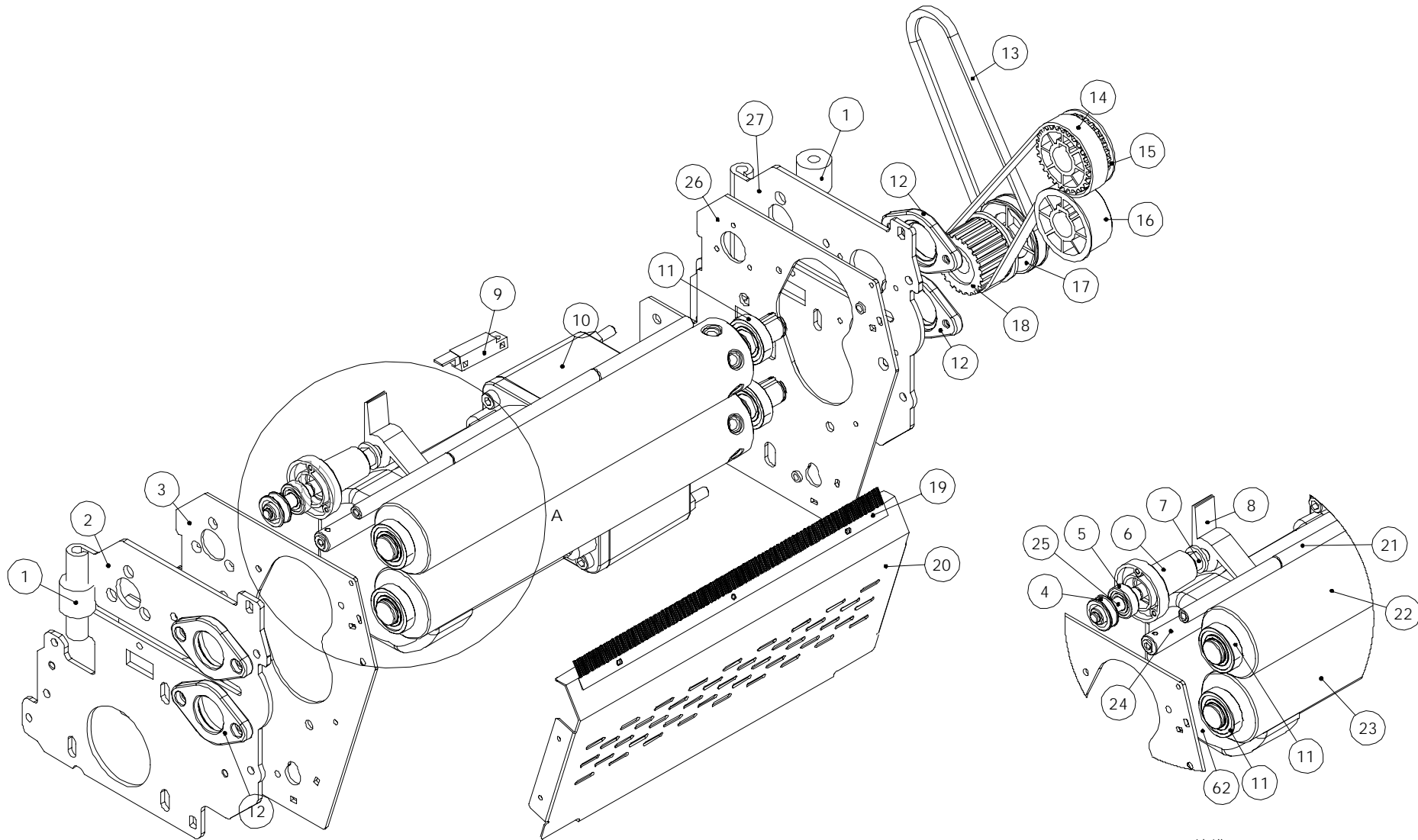

상세 A
배율 1:2

