

TL-200

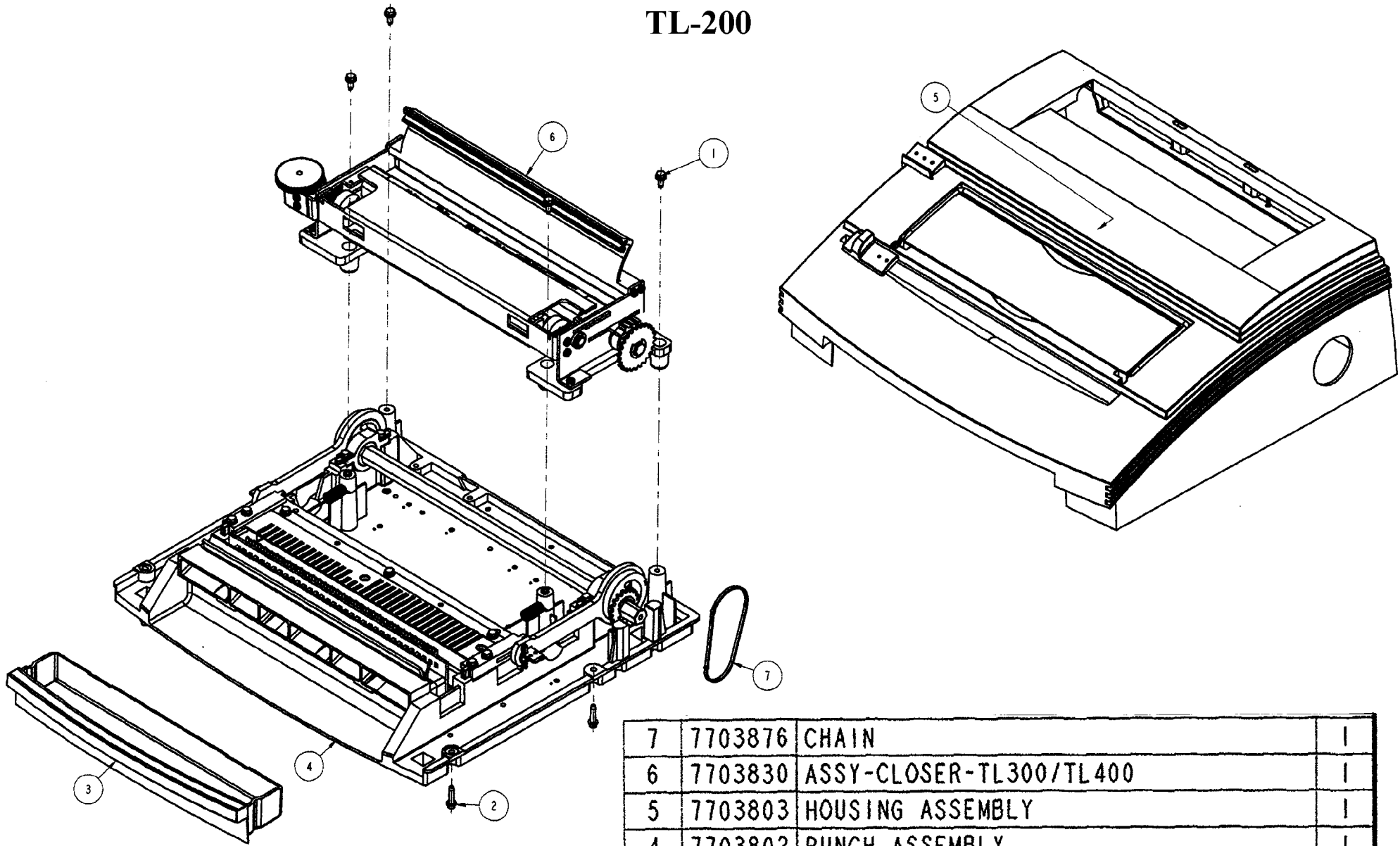

7	7703876	CHAIN	1
6	7703830	ASSY-CLOSER-TL300/TL400	1
5	7703803	HOUSING ASSEMBLY	1
4	7703802	PUNCH ASSEMBLY	1
3	7703570	CHIP TRAY	1
2	1911001	10-32 X 3/4 SEMS WSH SKT HD SCR	4
1	1907105	10-32x1/2 SEMS HX WSH HD TAP SCR	4
ITEM	PART NO.	DESCRIPTION	QTY.

TL-200

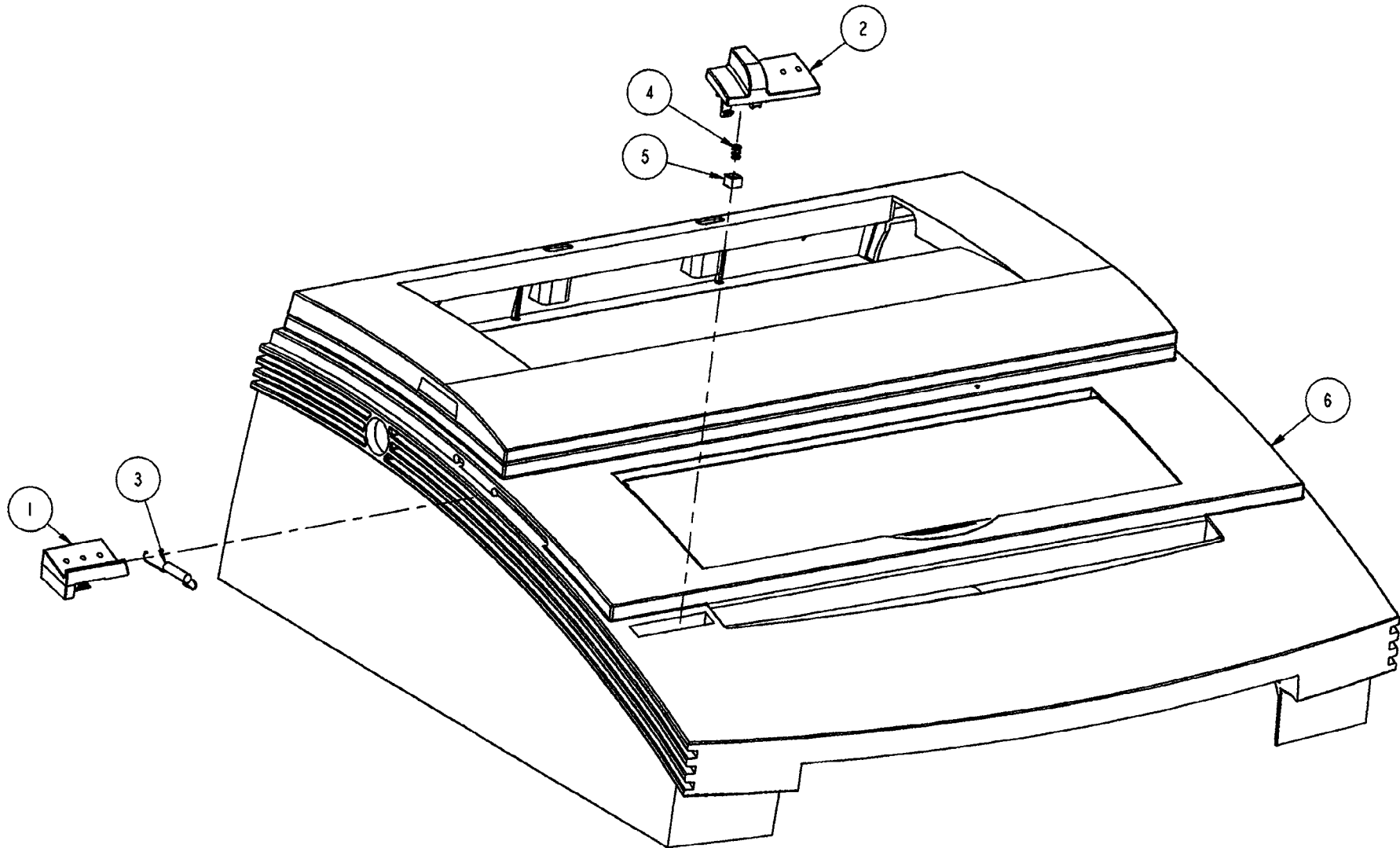

6	7703827	HOUSING, FINISHED	1
5	7703578	SLIDE, EDGE GUIDE	1
4	7703577	SPRING, EDGEGUIDE	1
3	7703575	SPRING, BINDER SIZER	1
2	7703574	EDGE GUIDE	1
1	7703573	BINDER SIZER	1
ITEM	PART NO.	DESCRIPTION	QTY.

TL-200

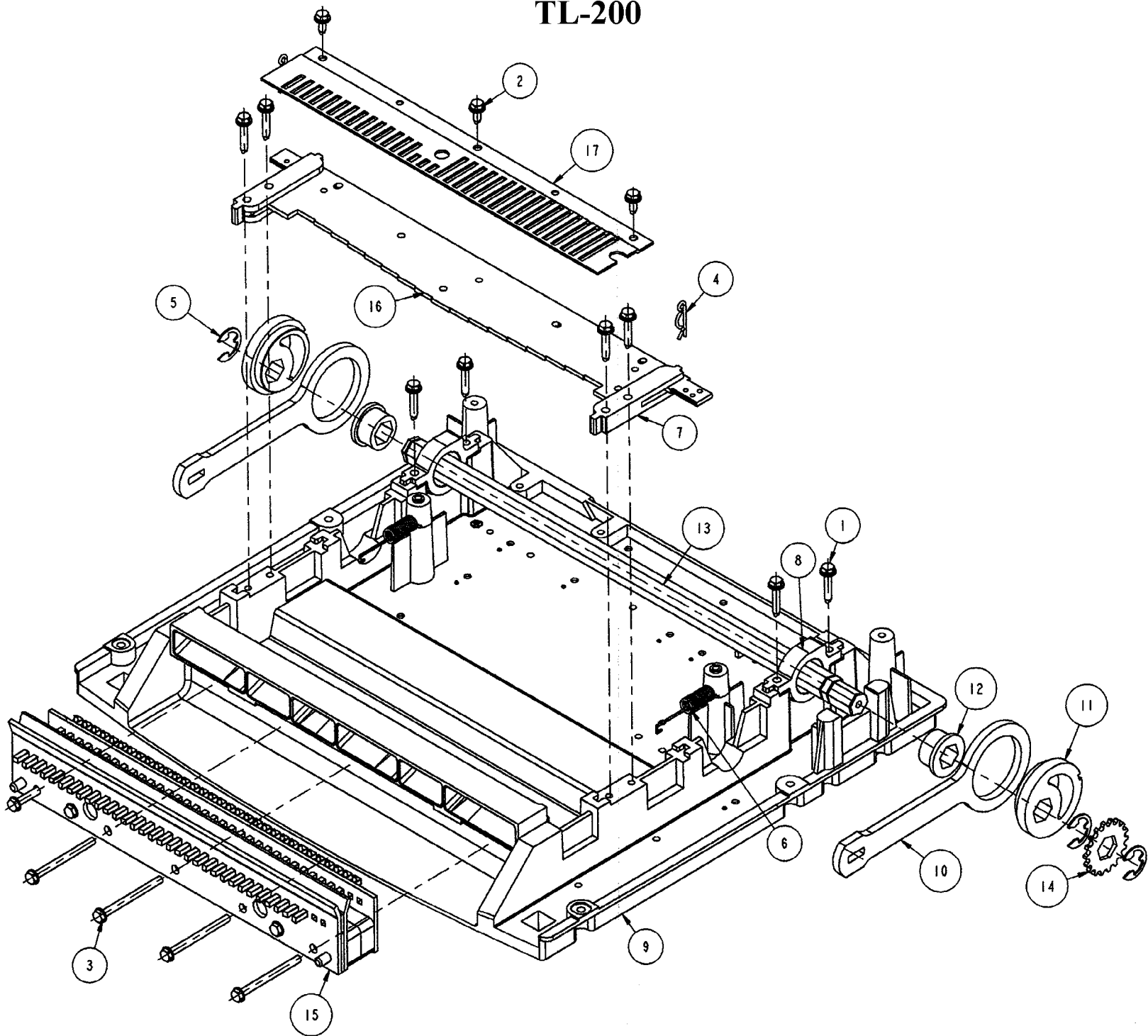

TL-200

17	7703849	STRIPPER	1
16	7703838	PRESSURE BAR	1
15	7703835	DIE SET ASM. WIRE	1
14	7703831	SPROCKET LOWER	1
13	7703565	SHAFT	1
12	7703548	BEARING	2
11	7703547	ECCENTRIC	2
10	7703544	CONNECTING LINK	2
9	7703542	BASE, PUNCH	1
8	7703541	BEARING CAP	2
7	7703540	SLIDE	2
6	7703533	SPRING, HANDLE	2
5	1930554	E-CLIP	3
4	1930251	HAIR PIN CLIP	2
3	1907411	10-32x2 1/4 SEMS HX WSH HD MACH SCR	5
2	1907105	10-32x1/2 SEMS HX WSH HD TAP SCR	3
1	1907103	10-32x1 SEMS HX WSH HD TAP SCR	8
ITEM	PART NO.	DESCRIPTION	QTY.

TL-200

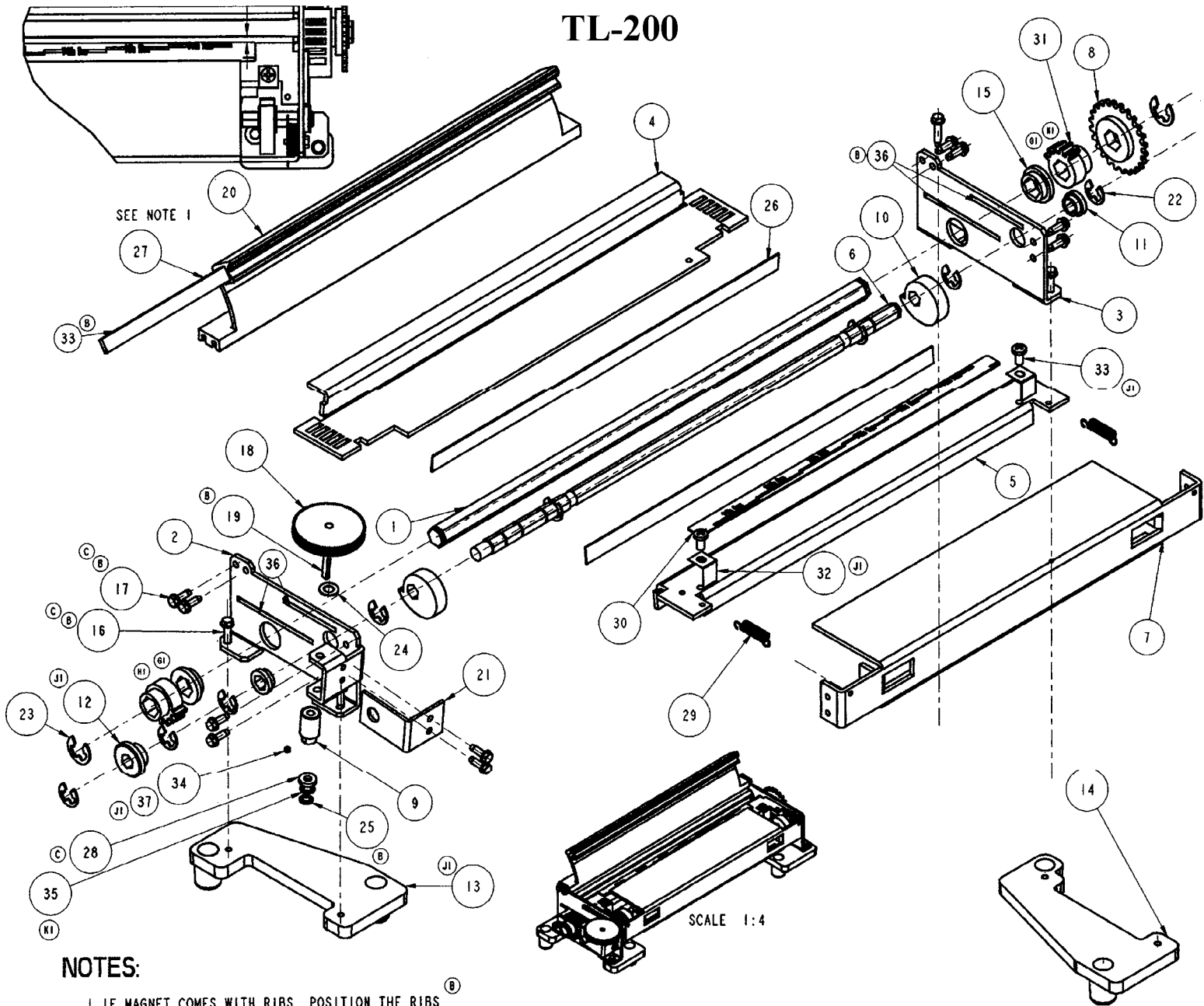

NOTES:

1. IF MAGNET COMES WITH RIBS. POSITION THE RIBS TO THE BACK OF THE MACHINE. ^(B)

^(J1) ^(F) 2. ADD SHIM (7703585) TO ADJUSTABLE CLAMP BETWEEN CAM IF REQUIRED TO CORRECT CLOSER SKEW.

TL-200

REVISIONS					
LETTER	E.C.N.	CHANGE	DATE	DR BY	CK'D BY
A	9664	RELEASE	7/20/98	MA	JF
B	9727	SEE ECO	10/4/98	MA	JF
C	9769	SEE ECO-NEW SCREWS, WASHER	12/3/98	VS	
D	9815	SEE ECO-1925214 QTY WAS 5	12/3/98	VS	
E	E09841	SEE ECO-ADJ CLAMP 7703819 WAS 7703846	6/3/99	MA	
F	E09858	SEE ECO-ADDED SHIM #7703818 & NOTE-2	6/16/99	MA	
GI	E10334	7703912 & 7703913 WAS 7703848	4/18/01	OP	
HI	E10346	7703915 WAS 7703912; 7703914 WAS 7703847	4/30/01	OP	
J1	E10588	7703507 WAS 7703896; 7703506 WAS 7703895 7703585 WAS 7703818; ADD ITEMS 33, 34, 37	3/26/02	PK	
K1	E10606	ADDED WASHER # 1925803	6/3/02	OP	

(J1)	37	1960524	LOCTITE 242	.001
(B)	36	1960525	LOCTITE 495	.01
(B)	35	1961503	LUBRIPLATE #130-AA	.001
(K1)	35	1925803	#10 STEEL INTERNAL LOCK WASHER	1
(J1)	34	1900019	SET SCREW #6-32x1/8, CONIC POINT	1
(J1)	33	1908500	SCR. 10-32x3/8 PHL. PAN HD THRD FORM.	2
(J1) (F)	32	7703585	SHIM, CLOSER TL (SEE NOTE 2)	2
(HI) (G1)	31	7703915	DRIVE GEAR	2
	30	7703824	LABEL, CLOSER ADJUST	1
(B)	29	1935309	SPRING	2
	28	7703842	WASHER, WORM	1
	27	7703828	MAGNET	1
	26	7703826	RUBBER STRIP	2
	25	1932510	E-CLIP	1
(D)	24	1925214	WASHER	1
	23	1930522	E-CLIP	2
	22	1930516	E-CLIP	8
	21	7703829	BRACKET, GEAR SUPPORT	1
	20	7703887	WIRE HOLDER	1
	19	7703886	SHAFT, WORM	1
	18	7703893	WHEEL-WORM GEAR	1
(C)	17	1907204	SCR 8-32X1/2 SEMS HX WSHD	10
(C)	16	1907203	SCR 8-32X3/4 SEMS HX WSHD	4
(G1)	15	7703913	BUSHING TL CLOSER	2
	14	7703845	BASE, RIGHT	1
	13	7703844	BASE, LEFT	1
(J1) (B)	12	7703506	WORM GEAR METAL TL CLOSER	1
	11	7703839	BEARING, CAM SHAFT	2
	10	7703840	CAM	2
(J1)	9	7703507	WORM METAL TL CLOSER	1
	8	7703897	SPROCKET, CLOSER	1
	7	7703841	BRACE	1
	6	7703843	SHAFT, CAM	1
(HI) (E)	5	7703819	ADJUSTABLE CLAMP	1
	4	7703914	DRIVE CLAMP	1
	3	7703891	SIDE FRAME RIGHT	1
	2	7703890	SIDE FRAME LEFT	1
	1	7703889	MAIN SHAFT	1
	ITEM	PART NO.	DESCRIPTION	QTY.

TL-200

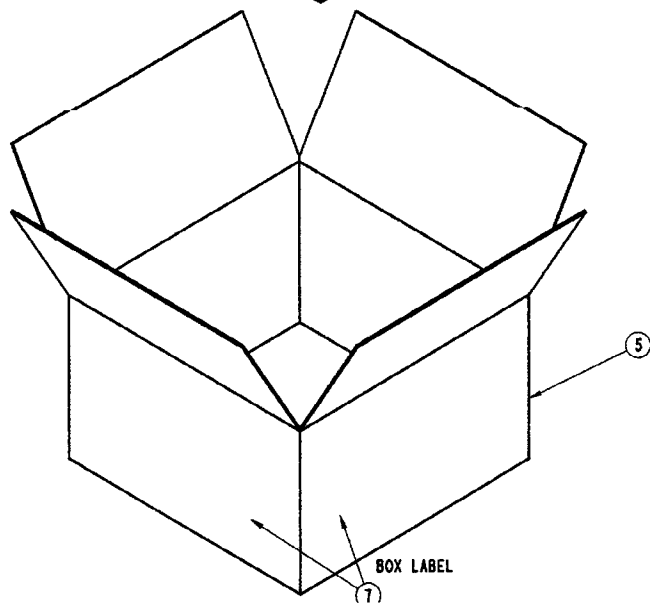
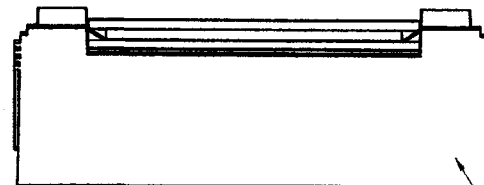
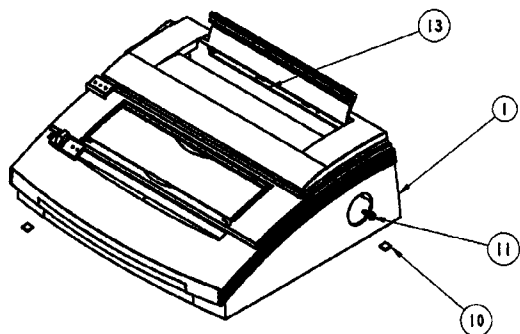
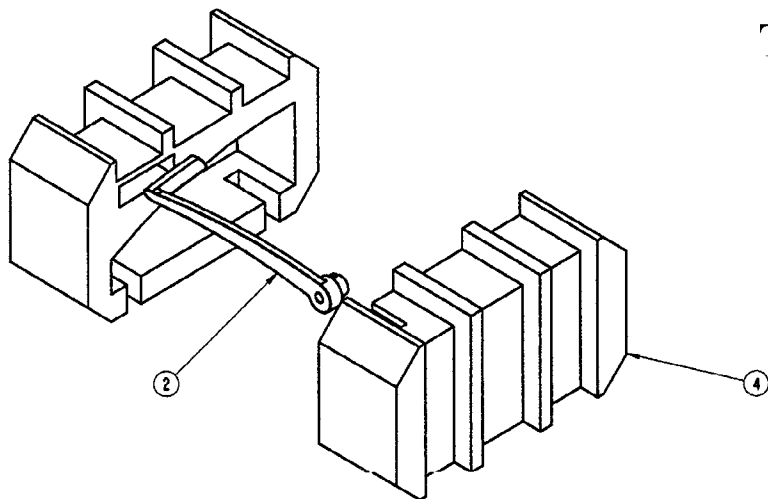

14.				
13.	7703806	SHIPPING BLOCK	1.0	
12.	7703505	HANDLE INSTAL. INSTR.	1.0	
11.	1907404	S* 10-32X1/2 HHS (SE	1.0	
10.	7703552	FOOT	4.0	
9.	1155022	WARRANTY CARDS 90DAY	1.0	
8.	7703804	OPERATING INSRUTIONS	1.0	
7.	1155024	MAST LISTING NAMEPLATE	1.0	
6.	1963141	S* TAPE 2" X 3000' PK	5.0	
5.	7703679	CARTON P400	1.0	
4.	7703580	FOAM END CAP NOPASET	1.0	
3.	7703881	PAPER SUPPORT	1.0	
2.	7703535	HANDLE PUNCH	1.0	
1.	7703801	D.B. TL200, F.ASY. DOM.	1.0	
ITEM NO.	PART NO.	DESCRIPTION	QTY.	ZONE

7
NAMEPLAT

7
BOX LABEL