

---

# 62FM Laminator

## INSTALLATION & OPERATION MANUAL

Document Number: 930-124 REV: - REV DATE: 11-24-04

Do not duplicate without written permission.

---





# TABLE OF CONTENTS

## 1. Safety

Important Safety Instructions ..... 1-1  
 Important Safeguards ..... 1-1  
     General ..... 1-1  
     Electrical ..... 1-2  
 Service ..... 1-2

## 2. Warranty

Limited 90-Day Warranty ..... 2-1

## 3. Specifications

Laminator Specifications ..... 3-1  
 FCC Note ..... 3-2  
 Intended Films and Applications ..... 3-2  
     Thermal and PSA Films ..... 3-2  
     Applications ..... 3-2

## 4. Installation

Pre-Installation ..... 4-1  
 Installation ..... 4-1

## 5. Control Guide

Control Panel ..... 5-1  
     Control Panel Display ..... 5-1  
     Roller Position Indicator ..... 5-1  
     Ready/Wait Indicator ..... 5-1  
     Positioning Indicator ..... 5-1  
     Master Dial ..... 5-1  
     Top Temp. .... 5-1  
     Bottom Temp. .... 5-1  
     Press/Release ..... 5-1  
     Cooling ..... 5-1  
     Job ..... 5-1  
     Speed ..... 5-2  
     Rev ..... 5-2  
     Stop ..... 5-2  
     Run ..... 5-2  
     Rewinder Selection Switch ..... 5-2  
     Upper Rewinder Direction Switch ..... 5-2  
     Lower Rewinder Direction Switch ..... 5-2  
     Rear Control Switch ..... 5-3  
     Enable Rear Control Switch ..... 5-3  
     Disable Rear Control Switch ..... 5-3  
     Foot SW Enable ..... 5-3  
 Features ..... 5-4  
     Power I/O (On/Off) ..... 5-4  
     Emergency Stop ..... 5-4  
     Safety Shield ..... 5-4  
         Safety Shield Interlock Latch ..... 5-5  
     Feed Table ..... 5-5

Heat Rollers ..... 5-5  
 Film Shaft ..... 5-5  
 Lower Shaft Cradle ..... 5-5  
 Tension Adjustment Knobs ..... 5-5  
 Rewind Shaft ..... 5-5  
 Rewind Tube ..... 5-5  
 Rewind Adaptors ..... 5-5  
 Idler Bar ..... 5-6  
 Chill Idler ..... 5-6  
 Cooling Fan ..... 5-6  
 Pull Rollers ..... 5-6  
 Rear Table ..... 5-6  
 Core Chucks ..... 5-6  
 Separator Bar ..... 5-6  
 Roller Handle ..... 5-6  
 Film Web ..... 5-6  
 Nip Point ..... 5-6  
 Foot switch ..... 5-7

## 6. Operating Instructions

General Operation ..... 1  
     Standby Mode ..... 2  
     Setting Jobs Into Memory ..... 2  
 Film Loading & Threading ..... 2  
 Loading Film ..... 3  
 Loading Thermal Film ..... 3  
     Top Thermal Film ..... 3  
     Bottom Thermal Film ..... 4  
 Loading AccuShield Film ..... 4  
 Loading PSA Film ..... 5  
     Top PSA Film ..... 5  
     Bottom PSA Mount Film ..... 6  
 Loading Mount Adhesive ..... 6  
     Top Mount Adhesive ..... 6  
     Bottom Mount Adhesive ..... 7  
 Threading Card Procedure ..... 7  
 Tacking New Film to Existing Film ..... 8  
 To Unweb the Laminator ..... 9  
 Clearing a Film Jam (Wrap-up) ..... 9  
 Applications ..... 10  
     Tips for Pre-coating Boards ..... 10  
     Tips for Using the Rear Rollers ..... 10  
     Tips for Mounting on Pre-coated Boards ..... 11  
     Tips for PSA Encapsulation ..... 11  
     Tips for Thermal Encapsulation ..... 11  
     Tips for AccuShield ..... 12  
 Lamination Guide ..... 12  
     Basic Rules ..... 12  
     Film Tension ..... 13  
     Heat ..... 13  
     Output ..... 13

**7. Operator Maintenance** \_\_\_\_\_

Maintaining the 62FM Laminator ..... 7-1  
    Cleaning the Rollers..... 7-1  
Troubleshooting ..... 7-2

# 1. SAFETY

## IMPORTANT SAFETY INSTRUCTIONS

Your safety as well as the safety of others is important. In this instruction manual and on the product, you will find important safety messages regarding the product. Read these messages carefully. Read all of the instructions and save these instructions for later use.

 **WARNING:** The safety alert symbol precedes each safety message in this instruction manual. The symbol indicates a potential personal safety hazard to you or others.

 This safety alert symbol indicates a potential electrical shock. It warns you to not open the laminator and expose yourself to hazardous voltage.

The following warnings are found upon this product.

⚠ ADVERTENCIA	⚠ ATTENTION		⚠ WARNING
Riesgo de choque eléctrico. No abra: Adentro no hay piezas reparables por el usuario. Mantenimiento solamente por personal calificado.	Risque de secousse électrique. Ne pas ouvrir. Pas de pièces réparables par l'utilisateur. Entretien seulement par personnel qualifié.		Electrical shock hazard. Do not open. No user serviceable parts inside. Refer servicing to qualified service personnel.

This safety message means that you could be seriously hurt or killed if you open the product and expose yourself to hazardous voltage.

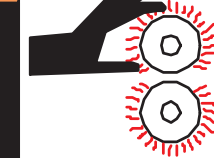
⚠ ADVERTENCIA	⚠ ATTENTION		⚠ CAUTION
RODILLOS CALIENTES. PUNTO DE PINCHAMIENTO. Mantener manos y ropa a distancia.	ROULEAUX CHAUDS. POINT DE PINCEMENT. Tenir mains et vêtements à l'écart.		HOT ROLLS. PINCH POINT. Keep hands and clothing away.

This safety message means that you could be burned and your fingers and hands could be trapped and crushed in the hot rollers. Clothing, jewelry and long hair could be caught in the rollers and pull you into them.



Hot surface. Use caution as hot surface could cause burns.

## IMPORTANT SAFEGUARDS

 **WARNINGS:**

- Do not attempt to service or repair the laminator.
- Do not connect the laminator to an electrical supply or attempt to operate the laminator until you have completely read these instructions. Maintain these instructions in a convenient location for future reference.
- To guard against injury, the following safety precautions must be observed when installing and using the laminator.

Failure to observe these warnings could result in severe bodily damage or death.

## GENERAL

- Keep hands, long hair, loose clothing, and articles such as necklaces or ties away from the front of the heat and pull rollers to avoid entanglement and entrapment.
- The heat rollers can reach temperatures over 300 °F (150 °C). Avoid contact with the heat rollers during operation or shortly after power has been removed from the laminator.
- Do not use the laminator for other than its intended purpose.
- Avoid moving the laminator on uneven floor surfaces. Never tilt the laminator.
- Do not defeat or remove electrical and mechanical safety equipment such as interlocks, shields and guards.
- Do not insert objects unsuitable for lamination or expose the equipment to liquids.



The laminator should be connected only to a source of power as indicated in these instructions and on the serial plate located on the rear of the laminator. Contact an electrician should the attachment plug provided with the laminator not match the receptacles at your location.

 **CAUTION:** The receptacle must be located near the equipment and easily accessible.

Disconnect the plug from the receptacle and contact your dealer/distributor when one or more of the following has occurred.

- The power supply cord or attachment plug is damaged.
- Liquid has been spilled into the laminator.
- The laminator is malfunctioning after being mishandled.
- The laminator does not operate as described in these instructions.

## SERVICE

Perform only the routine maintenance procedures referred to in these instructions.

 **Warning:** Do not attempt to service or repair the laminator. Failure to observe this warning could result in severe bodily damage or death.

## 2. WARRANTY

---

### LIMITED 90-DAY WARRANTY

The Manufacturer warrants to the original purchaser for a period of ninety days on labor and one year on parts after installation that this laminator is free from defects in workmanship and material under normal use and service. The Manufacturer's obligation under this limited warranty is limited to replacement or repair, at The Manufacturer's option, of any part found defective by the Manufacturer without charge for material or labor.

THIS LIMITED WARRANTY IS IN LIEU OF ALL OTHER WARRANTIES EXPRESSED OR IMPLIED. WARRANTIES OF MERCHANTABILITY OR FITNESS FOR A PARTICULAR PURPOSE ARE EXPRESSLY EXCLUDED. ANY REPRESENTATIONS OR PROMISES INCONSISTENT WITH, OR IN ADDITION TO, THIS LIMITED WARRANTY ARE UNAUTHORIZED AND SHALL NOT BE BINDING UPON THE MANUFACTURER. IN NO EVENT SHALL THE MANUFACTURER BE LIABLE FOR ANY SPECIAL, INCIDENTAL, OR CONSEQUENTIAL DAMAGES, WHETHER OR NOT FORESEEABLE.

This limited warranty shall be void if the laminator has been misused; mishandled; damaged by negligence, by accident, during shipment, or due to exposure to extreme conditions; repaired, altered, moved, or installed by anyone other than the Manufacturer or its authorized agents; or if incompatible film was used. The Manufacturer's obligation under this limited warranty does not include routine maintenance, cleaning, adjustment, normal cosmetic or mechanical wear, or freight charges.

Without limiting the generality of the previous paragraph, the Manufacturer's obligation under this limited warranty does not include:

1. Damage to the rollers caused by knives, razors, or other sharp tools; by any foreign objects falling into the working area of the laminator; or by cleaning the laminator with solutions or materials that harm its surfaces;
2. Damage caused by adhesives; nor
3. Damage caused by lifting, tilting or attempting to position the laminator other than rolling it on its casters across even surfaces.





### 3. SPECIFICATIONS

#### LAMINATOR SPECIFICATIONS

**Operating Speed:**  
Up to 10 fpm (3 mpm)

**Max Temperature:**  
300 °F (150 °C)

**Max. Mounting Thickness:**  
1/2 in. (1.3 cm)

**Max. Film Width:**  
61 in. (155 cm)

**Dimensions (W X D X H)**  
**Unit alone:**

83 in. x 40.25 in. x 51.5 in.  
(211 cm x 102 cm x 131 cm)

**Shipping:** 85 in. x 43 in. x 62.5 in.  
(216 cm x 109 cm x 159 cm)

**Weight:**  
**Unit alone:** 1030 lb. (467 kg.)  
**Shipping:** 1250 lb. (567 kg.)

**Electrical Requirements:**

Refer to the serial plate located on the rear of the laminator for the specific electrical rating applicable to the unit.

**U.S. Receptacle:** NEMA 6-50R

**Voltage:** 220 V, 60 Hz

**Current:** 20.5 A

**Power:** 4500 W

**Phase:** 1

**Interrupting Capacity:** 1500 A

**Ambient Air Temperature:** 41 to 104 °F (5 to 40 °C)

**Humidity Rating:** 30 to 95% non-condensing

**Altitude Rating:** Up to 2540 Feet (1000 Meters Min..)

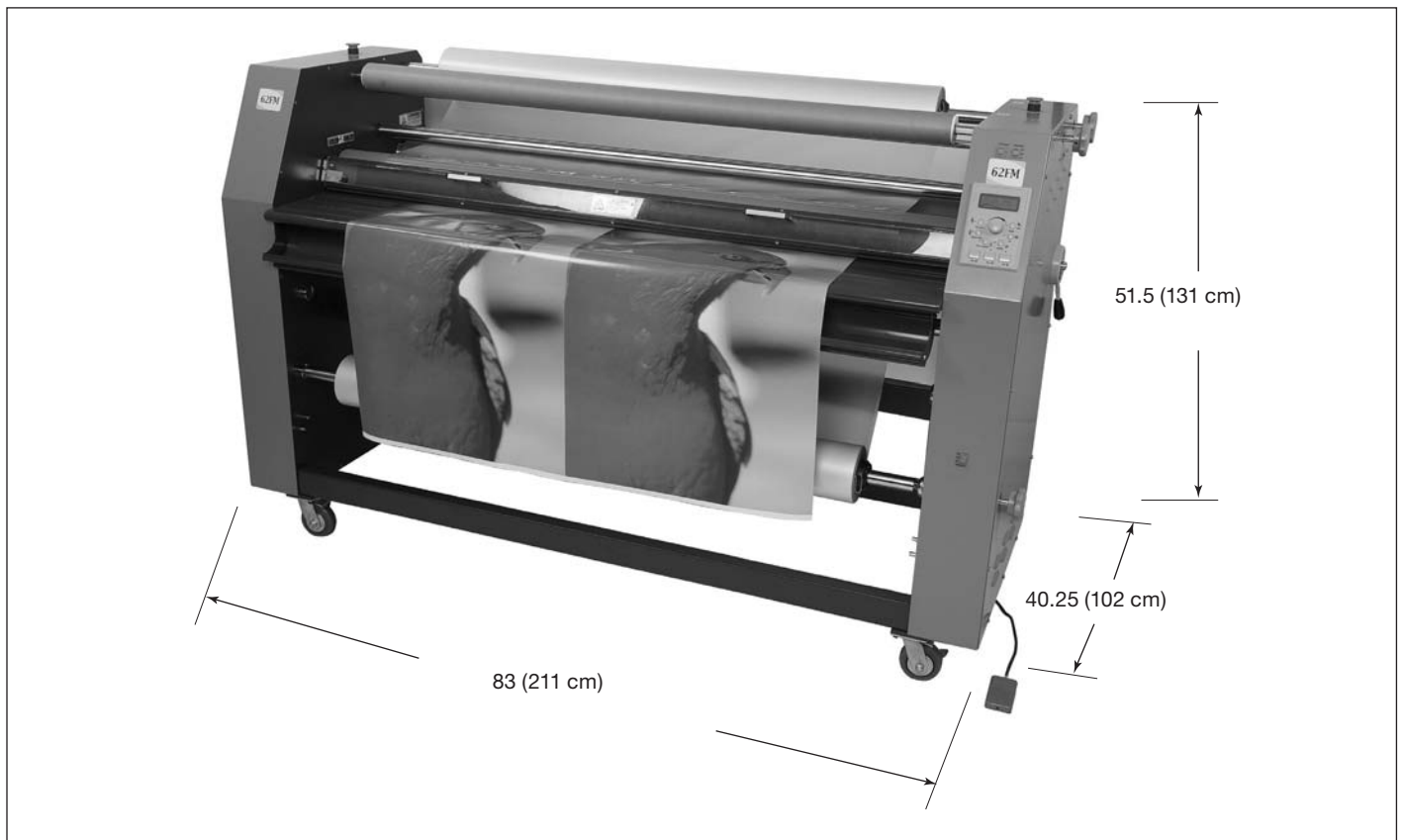

Fig. 3-1. 62FM Dimensions. (Shown in inches (cm).)

## FCC NOTE

This equipment has been tested and found to comply with the limits for a Class A digital device, pursuant to part 15 of the FCC Rules. These limits are designed to provide reasonable protection against harmful interference when the equipment is operated in a commercial environment. This equipment generates, uses, and can radiate radio frequency energy and, if not installed and used in accordance with the instruction manual, may cause harmful interference to radio communications. Operation of this equipment in a residential area is likely to cause harmful interference in which case the user will be required to correct the interference at his/her own expense.

Changes or modifications not expressly approved by the manufacturer could void the user's authority to operate the equipment.

This Class A digital apparatus complies with Canadian ICES-003.  
(Cet appareil numérique de la Classe A est conforme à la norme NMB-003 du Canada.)

## INTENDED FILMS AND APPLICATIONS

### THERMAL AND PSA FILMS

- Octiva™ Thermal
- Octiva™ Lo-Melt
- Artic™ Pressure Sensitive
- Artic™ Mounting Films
- AccuShield™

### APPLICATIONS

- Signs
- Posters
- Event Graphics
- Trade Show Graphics
- Presentations
- Banners
- Store Signage
- Floor Graphics
- Backlit Displays
- Vehicle Graphics

## 4. INSTALLATION

### PRE-INSTALLATION

Before 62FM laminator can be installed, ensure the following requirements are met;

1. Are doorways and hallways wide enough for the laminator to be moved to the installation site?
2. Is there ample room for the laminator?
  - a. A work area must be established that allows for operation in both the front and rear of the laminator and provides space for efficient material flow. (Fig. 4-1)
3. Is the environment appropriate for the laminator?
  - a. The laminator requires a clean, dust and vapor free environment to operate properly.
  - b. Avoid locating the laminator near sources of heat or cold. Avoid locating the laminator in the direct path of forced, heated or cooled air.

**CAUTION:** Air flow can cause uneven heating/ cooling of the rollers and result in poor output quality.

4. Have you contacted a certified electrician to wire the receptacle and ensure that adequate power is being supplied, having the appropriate capacity, over current protection and safety lockouts available?

### INSTALLATION

1. Shipping damage should be brought to the immediate attention of the delivering carrier.
2. With assistance, carefully roll the laminator into position over flat and even surfaces.
3. The laminator should be positioned to allow exiting film to flow freely to the floor or a work table. Accumulation of laminate immediately behind the laminator as it exits the equipment may cause the film to wrap around the pull rollers, resulting in a jammed condition.
4. Once the laminator has been properly positioned, lock the casters in place. Locking the casters prevents the machine from rolling during set up, operation, and servicing.

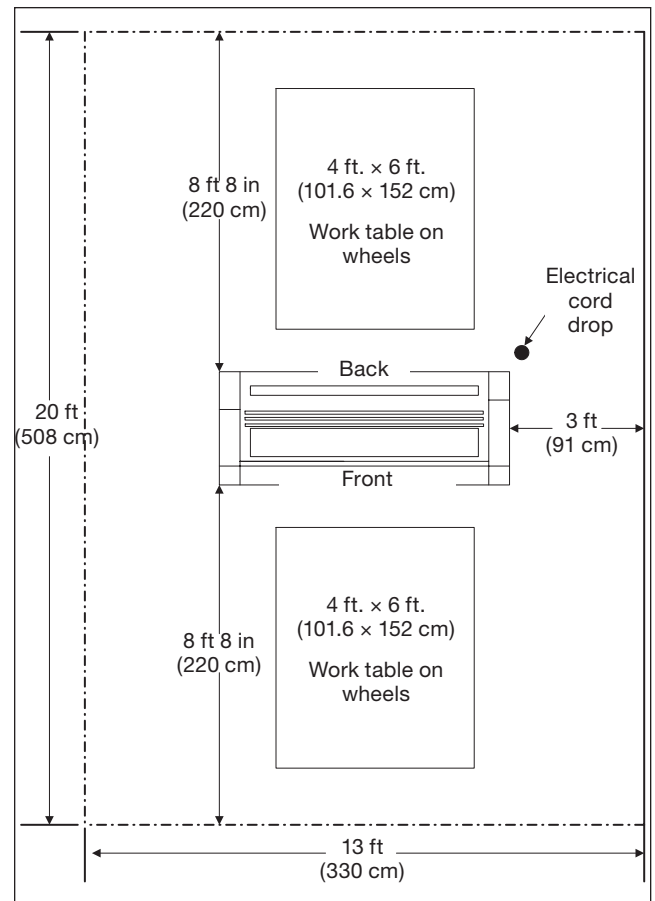

Fig. 4-1. Space Requirements.

5. The heaters must be installed by a qualified service technician.
6. Connect the attachment plug provided with the laminator to a suitably grounded outlet. Avoid connecting other equipment to the same branch circuit to which the laminator is connected, as this may result in nuisance tripping of circuit breakers or blowing fuses.



## 5. CONTROL GUIDE

### CONTROL PANEL

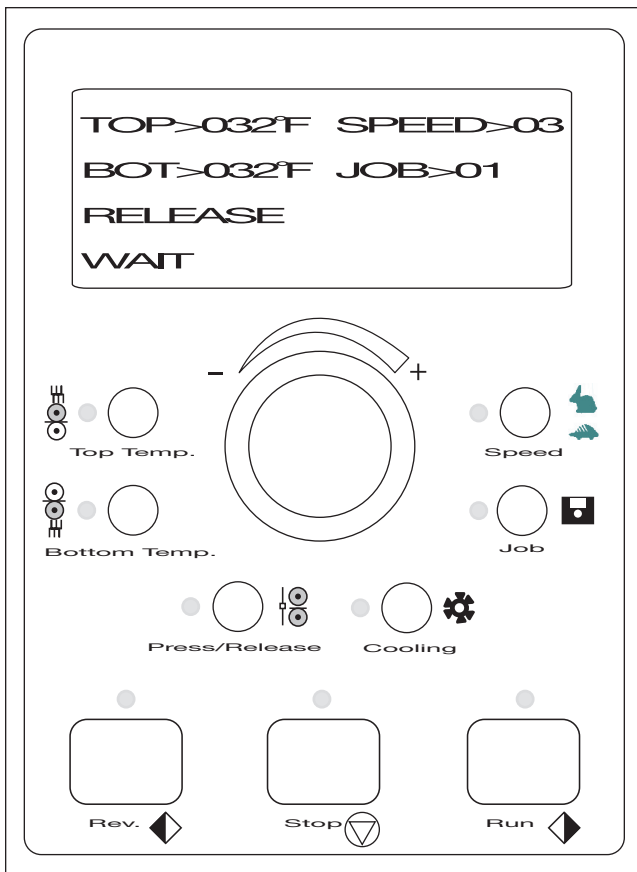

Fig. 5-1. Control Panel.

### CONTROL PANEL DISPLAY

Illuminates when the laminator is plugged in and **POWER I/O** is in the on, (I), position. Displays settings for top heater, bottom heater, speed, job, mode, and ready/wait status and roller position indicator.

### ROLLER POSITION INDICATOR

Displays the current main roller position. In Fig. 5-1, the roller is shown in the **Release** position. Refer to *Roller Handle* for more information.

### READY/WAIT INDICATOR

**READY** appears when actual temperature is equal to (+/- 5) set temperature. **WAIT** appears when actual temperature is lower or higher than the set temperature.

### POSITIONING INDICATOR

**Positioning...** appears in place of the ready/wait indicator any time the main rollers are traveling in an upward or downward motion.

### MASTER DIAL

Increases (+) or decreases (-) the numeric value for the selected setting when turned. Press and hold the dial to display actual temperature of top and bottom main rollers.

### TOP TEMP.

When pressed, permits increasing or decreasing of the top temperature by turning the **Master Dial** and is indicated on the control panel display. Range is room temperature up to 300 °F (150 °C).

### BOTTOM TEMP.

When pressed, permits increasing or decreasing of the bottom temperature by turning the **MASTER DIAL** and is indicated on the control panel display. Range is room temperature up to 300 °F (150 °C).

### PRESS/RELEASE

When pressed, raises the upper main roller overriding the pull roller handle setting. When pressed again, reverts to current pull roller handle setting.

### COOLING

When pressed, turns on the cooling fans. When pressed again, turns off the cooling fans.

### JOB

When pressed, permits scrolling of job numbers by turning the **MASTER DIAL** and is indicated on the control panel display. Range is 1 to 10. Job 10 is reserved for running AccuShield material.

To store parameters for a particular job number, select the desired job number location, enter the upper and lower temperatures and speed, then press **Job**.

## SPEED

When pressed, permits increasing or decreasing of speed by turning the **MASTER DIAL** and is indicated on the control panel display. Range is 1 to 10.

## REV

When pressed and held, reverses roller movement to clear film jams and wrap-ups.

## STOP

Stops the movement of the rollers.

## RUN

When pressed, activates rollers for normal operation.

## REWINDER SELECTION SWITCH

These switches enable the operator to control the function of the upper rewind/unwind shafts.



Fig. 5-2. Rewinder Selection Switches.

**I** In this position, turns the power on to the upper front rewind/unwind shaft.

 In this position, neither the upper front or upper rear rewind/unwind shaft is selected for motor power.

**II** In this position, turns the power on to the upper rear rewind/ unwind shaft.

## UPPER REWINDER DIRECTION SWITCH

This switch enables the operator to control the direction of the upper rewind/unwind shafts.

**FWD:** In this position, the motor runs in a forward direction.

**STOP:** Stops the rewinder motor for the rewind/unwind shaft selected.

**REV.:** In this position, the motor runs in a reverse direction.

## LOWER REWINDER DIRECTION SWITCH

(Not shown.) This switch enables the operator to control the direction of the lower rewind/unwind shaft.

**FWD.:** In this position, the motor runs in a forward direction.

**STOP:** Stops the rewinder motor for the rewind/unwind shaft selected.

**REV.** In this position, the motor runs in a reverse direction.

## REAR CONTROL SWITCH

This switch enables the operator to run jobs from the rear operating position of the laminator when rear controls are enabled.

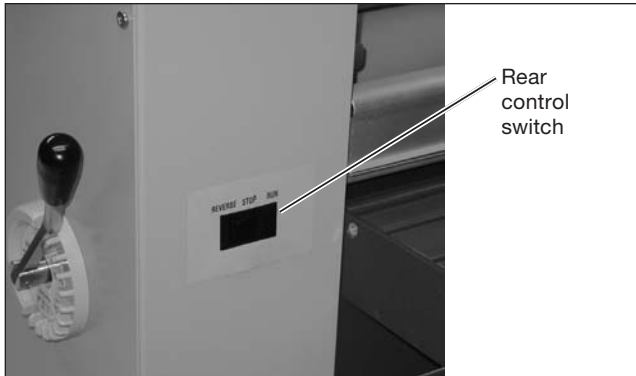

Fig. 5-3. Rear Control Switch.

**REVERSE:** In this position, the rollers turn from the front operating position towards the rear operating position.

**STOP:** Stops the movement of the rollers.

**RUN:** In this position, the rollers turn from the rear operating position towards the front operating position.

## ENABLE REAR CONTROL SWITCH

To enable the rear control switch, press and hold **Job** until you hear a beep, approximately 3 seconds. **REAR CONTROL** replaces **READY/WAIT** on the control panel display.

## DISABLE REAR CONTROL SWITCH

Press and hold **Job** again to disable the rear control switch.

## FOOT SW ENABLE

In this mode permits operation using the foot switch. To enable the foot switch, press and hold the **STOP** button for three seconds. Repeat this process to disable it. Refer to *Foot switch* for operation.

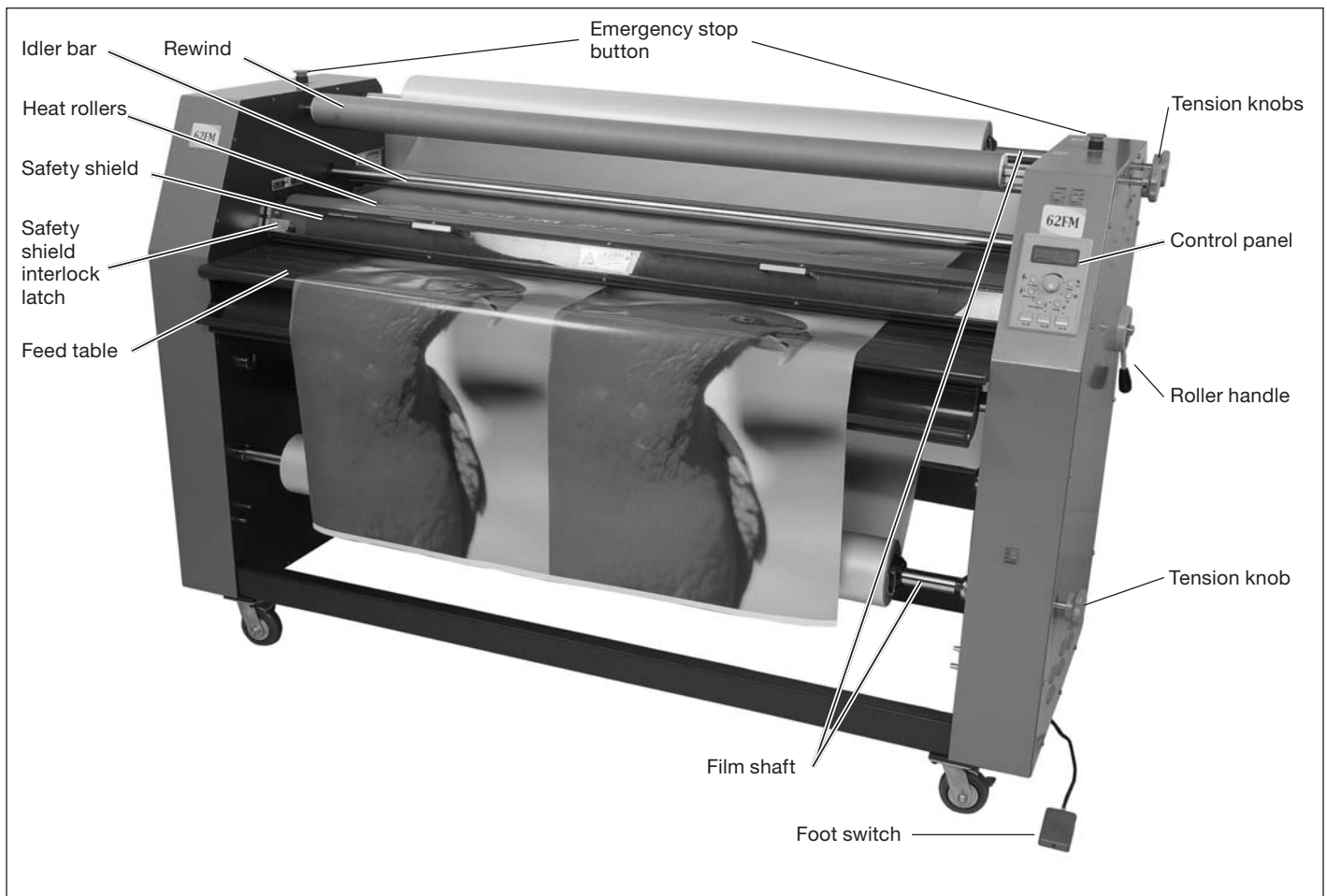

Fig. 5-4. 62FM Laminator Identification.

## FEATURES

### POWER I/O (ON/OFF)

Located at the back left of the machine applies power to the laminator. The control panel display will illuminate when switch is rotated to the "I" position. The off position, marked "O", removes power from the laminator.

### EMERGENCY STOP

Two emergency stop buttons exist on the laminator. One on each side of the upper cabinet. To engage, press either push button, roller movement is stopped. To disengage, turn the push button clockwise once the emergency condition has been resolved.

## SAFETY SHIELD

Prevents entanglement, entrapment and inadvertent contact with the heat rollers. **The laminator will operate in the continuous mode only when the safety shield is located in the fully locked position.** The foot switch operates the rollers at 3 fpm (0.9 mpm). The safety shield is removed only when you load films or clear jams.

To remove the safety shield, unlock the safety shield interlock latch and lift the safety shield up and away from the safety shield mounting pins.

This shield must also be used on the rear of the laminator when the laminator is operated from the rear.



### Safety Shield Interlock Latch

Used to lock the safety shield into position and activate an interlock switch. The interlock latch is located on the left side of the safety shield. When pushed to the full left, the safety shield is locked. When pushed to the full right, the safety shield is unlocked.

### FEED TABLE

The feed table is used to position items for lamination. The laminator will operate only when the feed table and feed table latch are properly installed. **The laminator will operate in the continuous mode only when the feed table is located in the fully locked position.** The foot switch operates the rollers at 3 fpm (0.9 mpm). The table is removed only when you load films or clear jams.

### HEAT ROLLERS

Silicone rubber coated steel tubes heat the laminating film and press the heated film to the items being laminated. Heat is provided by an internal heating element. The heat rollers are motor driven for ease of loading new film.

### FILM SHAFT

The film shaft holds the film supply on the machine.

To remove the film shaft, lift up on the round end of the unwind/ rewind shaft then pull the hex end of the shaft out and away from the laminator.

### LOWER SHAFT CRADLE

(Not shown.) Supports the left side of the lower shafts. To remove a shaft, lift the bearing end up and out of the cradle and then pull the other end of the shaft out.

### TENSION ADJUSTMENT KNOBS

**(Three):** Used to apply resistance to the film shaft.

To increase film shaft tension, turn the film shaft tension knob clockwise. Counter clockwise will decrease film shaft tension.

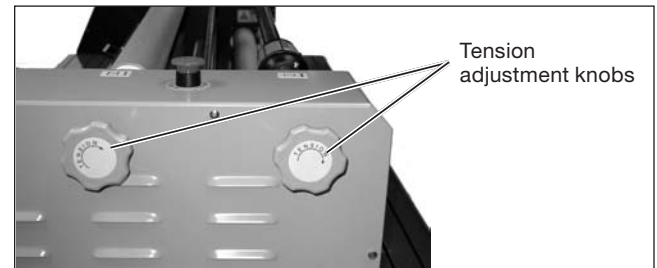

Fig. 5-5. Two of the Tension Adjustment Knobs.

### REWIND SHAFT

The rewind shaft holds the rewind tube on the machine.

### REWIND TUBE

The two rewind tubes located at the front of the machine are used to rewind release liners. The one located at the rear of the machine is used to rewind the finished product.

### REWIND ADAPTORS

(Not shown.) Hold and lock the rewind tube on the rewind shafts to prevent side to side shifting.

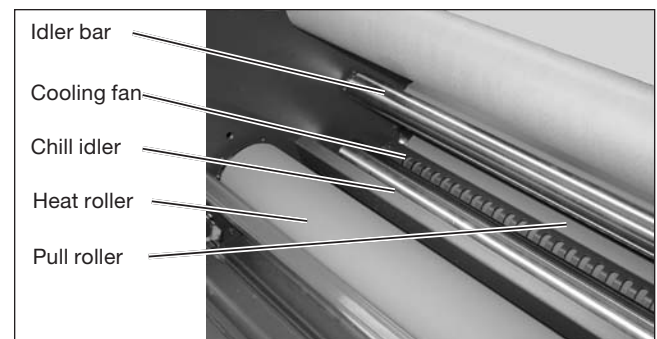

Fig. 5-6. Inside the 62FM, Viewed From the Front.

## IDLER BAR

The idler bars, located near each heat roller, are used to direct the film to the heat roller nip.

## CHILL IDLER

Assist in the cooling process of the web material as it exits the heat rollers.

To remove the chill idler, lift it out of its cradle and set aside, taking care to not damage the bearings.

## COOLING FAN

Assist in the cooling process by pushing unheated air onto the web

## PULL ROLLERS

The pull rollers, located at the back of the laminator, are motor driven. They simultaneously pull the film and improve the quality of the laminated item.

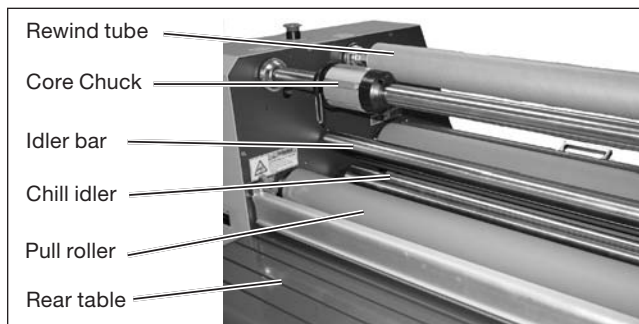

Fig. 5-7. Rear View of 62FM.

## REAR TABLE

Provides a working surface when operating the machine from the rear. This table may also be lowered when webbing for roll to roll applications.

To lower, slide the left and right side rear table latches to the unlatched position and lower the rear table.

## CORE CHUCKS

Hold and lock the rolls of film on the shafts to prevent side to side shifting.

## SEPARATOR BAR

(Optional) Required if running AccuShield material.

## ROLLER HANDLE

The roller handle manually sets the position of the pull rollers while simultaneously electronically setting the main rollers.

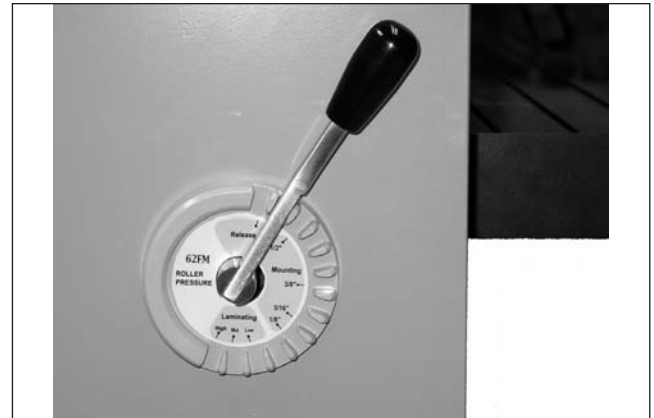

Fig 5-8. Roller Handle.

Available settings are;

- Release
- 1/2 in. Mounting
- 3/8 in. Mounting
- 3/16 in. Mounting
- 1/8 in. Mounting
- Low Laminating
- Mid Laminating
- High Laminating

## FILM WEB

(Not shown.) The path the laminating film and/or mounting film mounted on the machine takes through the machine.

## NIP POINT

The point at which the top and bottom rollers come into contact. The Nip Point of the heat rollers is the place at which the items for lamination are introduced into the laminator.

**FOOT SWITCH**

Operates the laminator when pressed and released by the operator's foot. Pressing it again stops the laminator. When the feed table is lowered or the safety shield is not latched, the foot switch must be pressed and held to move the rollers at 3 fpm (0.9 mpm).



## 6. OPERATING INSTRUCTIONS

### GENERAL OPERATION

For thermal processes, the heat rollers need to be brought up to the proper temperature before you load films or run items through the laminator. If the laminator will be idle for more than four hours, lower the temperature of both rollers to 180 °F (80 °C).

For PSA films and mounting processes, remove the chill idler.

1. The safety shield and feed table must be in the normal operating position.
2. Select a job mode and ensure the proper speed and temperatures are set.
3. Set the roller handle to one of the laminating positions.
4. Press the **Press/Release** button.  
The main rollers gap.

**WARNING:** Hot surfaces and pinch points. Keep fingers and hands away from the heat pressure and pull rollers. Clothing, jewelry and long hair could be caught in the rollers and pull you into them. Failure to adhere to this warning could result in serious personal injury.

5. Press the **Run** button.
6. Press the **Press/Release** button.  
The main rollers close.
7. Adjust unwind and rewind tensions as necessary.
8. Align the leading edge of the item square to the heat roller nip.

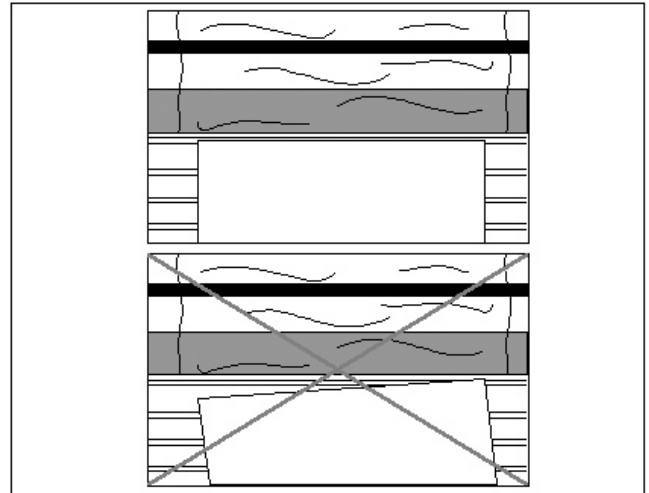

Fig 6-1. Aligning the Item With The Rollers.

9. With both hands, and an outward force, push the image slower than the speed of the rollers into the nip of the heat rollers.

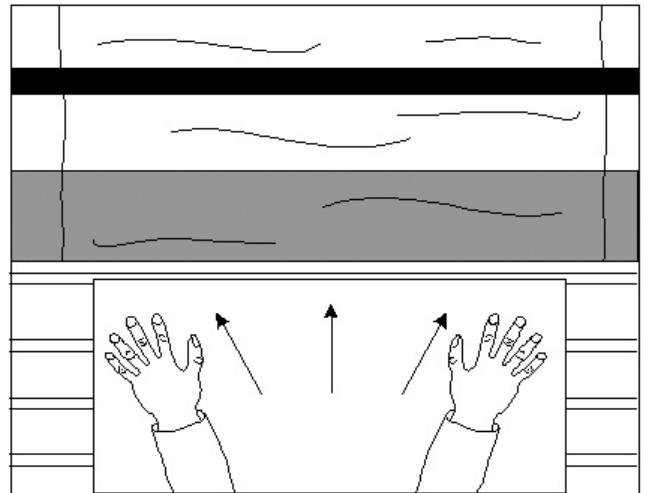

Fig. 6-2. Feeding Items Into the Laminator.

**CAUTION:** Avoid forcing the image into the main roller nip as this action will cause the corners of the leading edge to buckle and create a wave.

## STANDBY MODE

The 62FM automatically goes to standby mode after 3 hours of inactivity. At this time, the laminator beeps and the heat roller temperature is lowered to 180 °F (80 °C), if they were on. **STAND BY** blinks on the LCD. After another hour of inactivity, the heat is turned off. **POWER-OFF** blinks on the LCD.

To take the laminator out of standby mode, press the **Run** button. If the heat was lowered or turned off, you will have to wait until **READY** is displayed on the control panel.

**IMPORTANT:** Whenever the laminator will be idle for an hour or more, press the **Press/Release** button .

## SETTING JOBS INTO MEMORY

Job settings can be saved into memory for easy retrieval later.

### To save a job into memory:

1. Press the **Job** button and select a job number with the **MASTER DIAL**.
2. Set the temperature and speed for the job application.
3. Press the **Job** button again.

## FILM LOADING & THREADING

The top and bottom rolls of laminating film must be of the same width and be present simultaneously. A small amount of adhesive will “squeeze out” during lamination. Hardened adhesive deposits can damage the heat rollers. To avoid any damage, select **Low – Laminating** on the roller handle, rotate the rollers at slowest speed with heat on. Refer to the chapter entitled *Operator Maintenance* for instructions regarding removal of the accumulated adhesive.

Adhesive will deposit on the rollers if:

- Only one roll is used.
- Different widths of rolls are loaded together.
- Either roll is loaded adhesive side against a heat roller.
- One or both rolls of film are allowed to run completely off its core.

The adhesive side of the film is on the inner side of the web. The shiny side of clear film must contact the heat rollers. The dull side of the film contains the adhesive. Use extreme caution when loading delustered (matte) film as both sides appear dull.

Always change the top and bottom supply rolls at the same time. Near the end of each roll of laminating film is a label stating **Warning-End of Roll**. The appearance of this label on either the top or bottom roll requires that new rolls of film be installed as soon as the item presently being laminated completely exits the rear of the laminator. Do not introduce any additional items into the laminator when the warning label is visible.

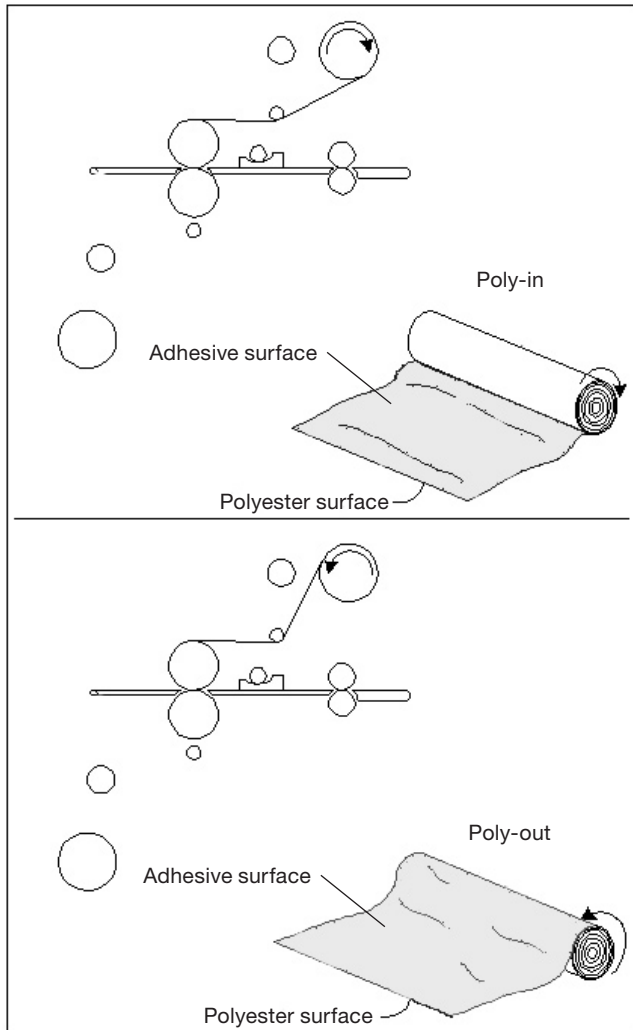

Fig. 6-3. Poly-in and Poly-out Configurations.

### LOADING FILM

1. Lift up on the round end, left side, of the unwind/rewind shaft.
2. Pull the hex end, right side, of the shaft out and away from the laminator.
3. Slide the roll of film onto the film shaft ensuring adhesive side is out.
4. Replace the shaft with the hex end in first then the round end.
5. Center the roll of film.

### LOADING THERMAL FILM

#### TOP THERMAL FILM

This procedure describes how to load the upper roll of film onto the laminator. Fig. 6-4 shows poly-in film and the upper rear unwind/rewind position for illustration purpose.

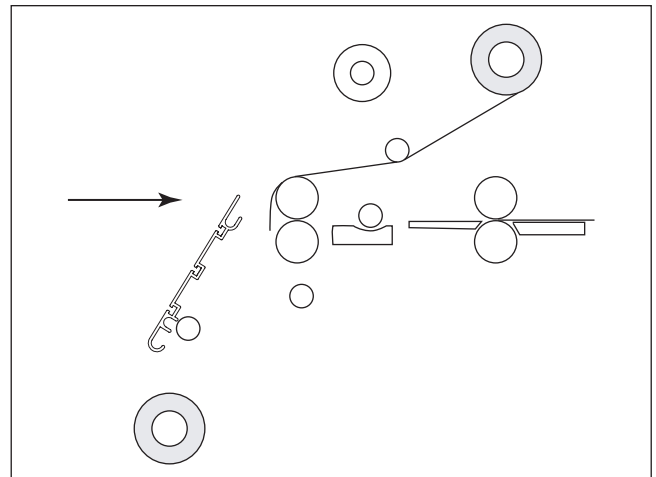

Fig. 6-4. Loading Top Thermal Film.

1. Turn the **Power I/O (On/Off)** to **ON (I)**.
2. Set top heat temperature for the film type you are using.
3. Ensure no brake tension is applied to the film shaft.
4. Remove the safety shield and pivot the feed table down.

5. Pull the top roll of film down under the idler bar and allow to drape over the top heat roller.
6. Reference one of the loading bottom material procedures.

### BOTTOM THERMAL FILM

This procedure describes how to load a roll of thermal film using the lower unwind position for encapsulation. At this point you should have an upper roll of thermal film loaded onto the laminator.

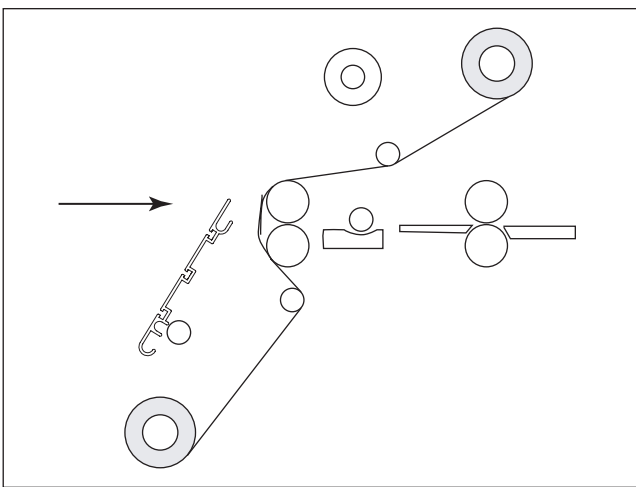

Fig. 6-5. Loading Bottom Thermal Film.

1. Ensure no brake tension is applied to the film shaft.
2. Guide the bottom film around the lower idler.
3. Adhere the film to the loaded upper roll of thermal film by pulling the film up towards the existing draped thermal film over the main rollers.

**NOTE:** You may follow this procedure to load a roll of kraft paper for single side lamination.

5. Reference *Threading Card Procedure*.

### LOADING ACCUSHIELD FILM

This procedure describes how to load a roll of AccuShield film and attach the liner to the take-up.

**IMPORTANT:** When starting to laminate, always start the rollers BEFORE applying pressure to the rollers to prevent AccuShield build up on the roller. When stopping, release the pressure on the rollers BEFORE stopping the motor.

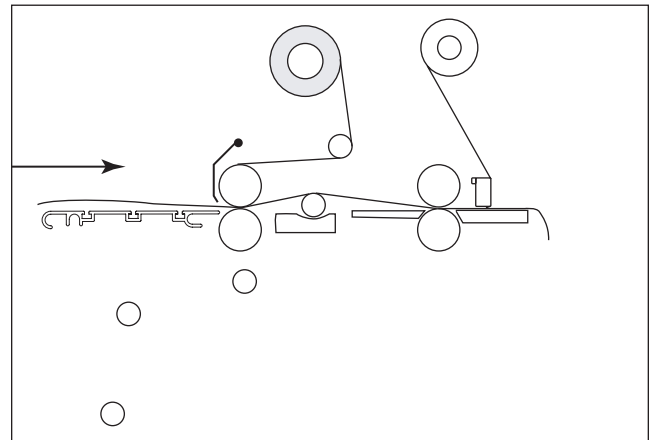

Fig. 6-6. Configuration for AccuShield Film.

1. Pull the film down, thread it under the idler bar and drape it over the top heat roller.

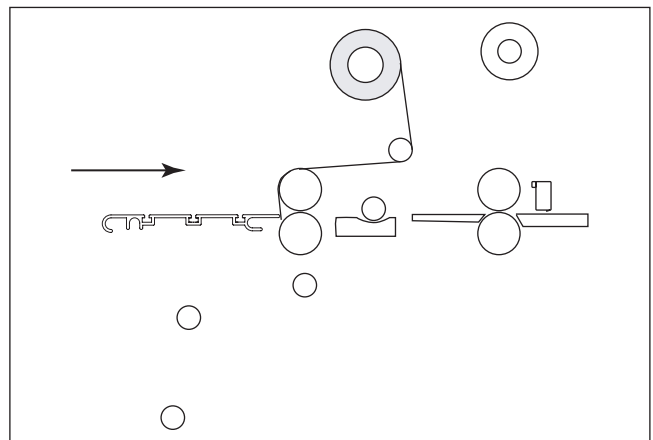

Fig. 6-7. AccuShield Draped Over the Top Heat Roller.

2. Press the straight edge of the threading card into the film at the nip until the card and film is slightly past the nip. The threading card for webbing AccuShield film can be any stiff print. The film should be wrapped around the leading edge of the card.



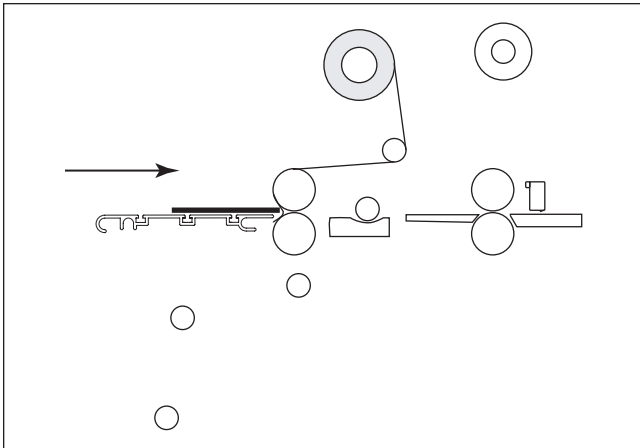

Fig. 6-8. Threading Card Inserted Into the Film.

3. Press the **RUN** button on the control panel.
4. Press the **Press/Release** button to apply pressure to the threading card and guide the card into the machine until the rollers pull it on its own.

**WARNING:** Keep your fingers and hands away from the nip point while the machine is running. They could be trapped and crushed in the rollers. Clothing, jewelry, and long hair could be caught in the rollers and pull you into them.

5. Release the card and ensure that the film and card are being pulled into the laminator. The card will guide the film into the rollers.
6. After the threading card exits the laminator, set the roller pressure handle to **Release**.
7. Press the **STOP** button.
8. Separate the release liner from the card.
9. Pull the film up to the take-up core and tape it to the core.
10. Replace the safety shield.

## LOADING PSA FILM

### TOP PSA FILM

This procedure describes how to load the upper roll of film onto the laminator. Fig. 6-9 shows PSA film and the upper rear unwind/rewind position for illustration purpose.

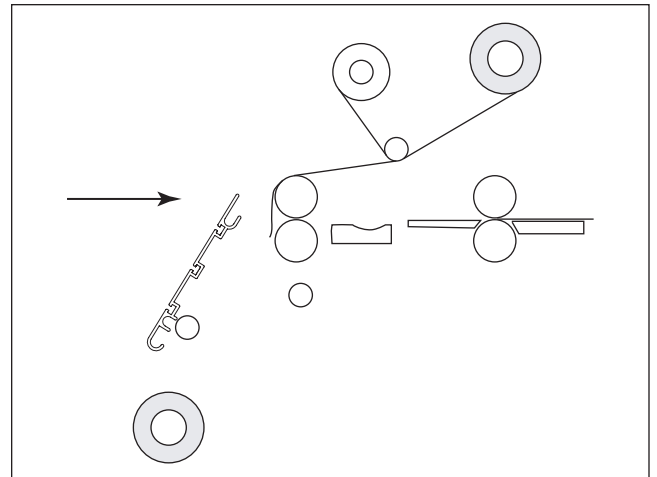

Fig. 6-9. Loading Top PSA Film.

1. Turn the **Power I/O (On/Off)** to **ON (I)**. If the laminator is already hot, turn it to the **OFF (O)** position and allow the unit to cool. Once cool, turn the laminator back on.
2. Ensure no brake tension is applied to the film shaft.
3. Remove the safety shield and pivot the feed table down.
4. Set the roll of film in the rear unwind/rewind position and the rewind tube in the front unwind/rewind position.
5. Pull the top roll of film down under the idler bar and up to the upper front rewind tube.
6. Place one piece of masking tape in the center of the film and secure to the rewind tube.
7. Make two full wraps around the rewind tube, then carefully score the laminate without cutting the release liner.
8. Pull the laminate down, allowing it to drape over the upper main roller.

9. Reference one of the loading bottom material procedures.

### BOTTOM PSA MOUNT FILM

This procedure describes how to load a roll of mount adhesive using the lower unwind position for decaling. At this point you should have an upper roll of PSA film loaded onto the laminator.

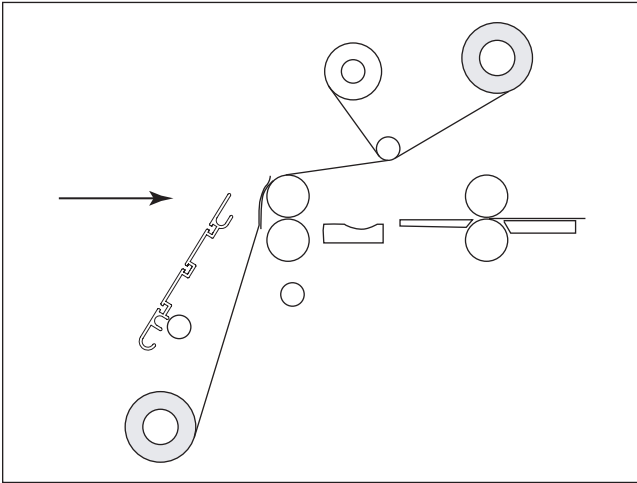

Fig. 6-10. Loading Bottom PSA Film Without Liner.

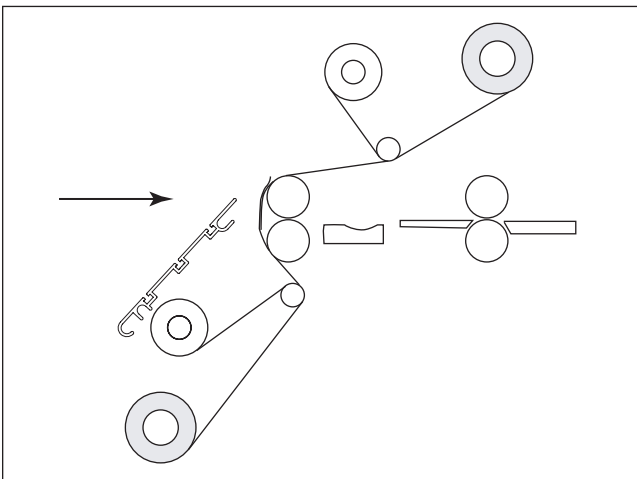

Fig. 6-11. Loading Bottom PSA Film With Liner.

1. Ensure no brake tension is applied to the film shaft.
2. Pull the lower roll of film around the lower idler bar and towards the lower rewind.
3. Place one piece of masking tape in the center of the film and secure to the rewind tube.

4. Make two full wraps around the rewind tube, then carefully score the laminate without cutting the release liner.
5. Adhere the lower PSA film to the loaded upper roll of film by pulling the film straight up towards the main rollers.
5. Reference *Threading Card Procedure* next.

### LOADING MOUNT ADHESIVE

#### TOP MOUNT ADHESIVE

This procedure describes how to load a roll of mount adhesive using the upper position for pre-coating.

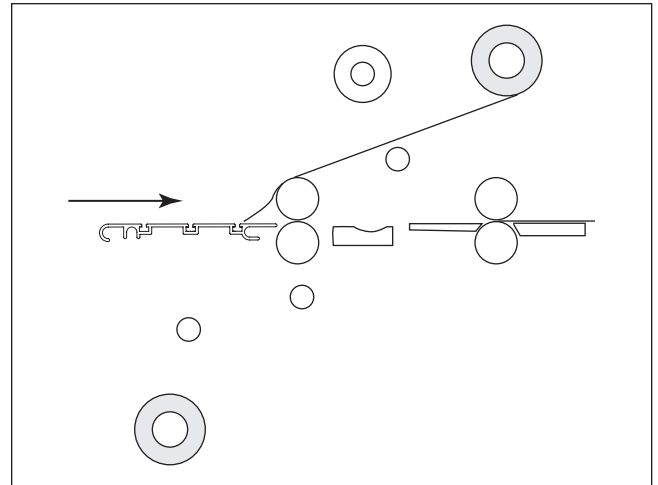

Fig. 6-12. Loading Mount Adhesive for Pre-Coating a Board.

1. Turn the **Power I/O** to **ON (I)**.  
If the laminator is already hot, turn it to the **OFF (O)** position and allow the unit to cool. Once cool, turn the laminator back on.
2. Ensure no brake tension is applied to the film shaft.
3. Remove the safety shield.
4. Set the roll of mount adhesive in the upper rear unwind/rewind position.
5. Pull the mount adhesive over the upper idler and upper main roller allowing the material to rest on the top of the feed table.
5. Reference *Threading Card Procedure* next.

## BOTTOM MOUNT ADHESIVE

This procedure describes how to load a roll of mount adhesive using the lower unwind position for decaling. At this point you should have an upper roll of film loaded onto the laminator.

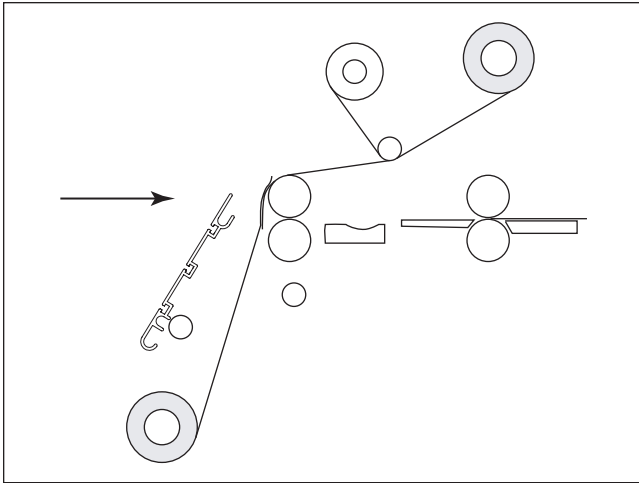

Fig. 6-13. Loading Bottom Mount Adhesive for Decaling.

1. Ensure no brake tension is applied to the film shaft.
2. Adhere the mount adhesive to the loaded upper roll of film by pulling the mount adhesive straight up towards the main rollers. Do not web around the lower idler.
3. Reference *Threading Card Procedure* next.

## THREADING CARD PROCEDURE

This procedure describes how to feed two loaded films through the main rollers. At this point you should have the upper lower rolls of film loaded onto the laminator with the appropriate material for your application. The figure shows threading for thermal (solid lines) and PSA (dashed lines) films.

**NOTE:** When loading PSA films, the chill idler must be removed.

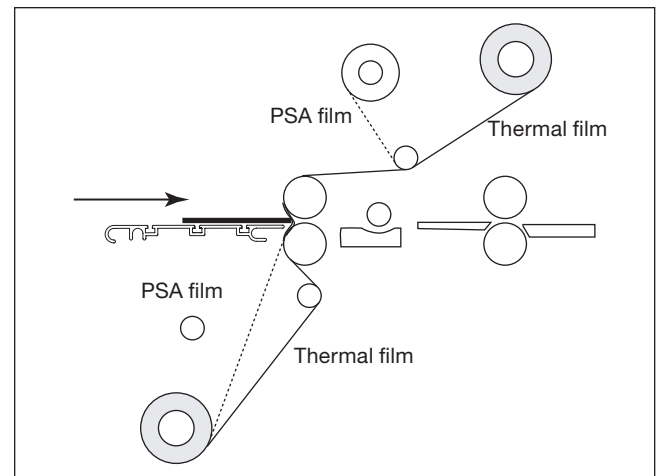

Fig. 6-14. Threading With a Threading Card.

1. Install the table and safety shield.
2. Push the threading card into the main roller nip. The threading card becomes sandwiched between the upper and lower loaded films.
3. Set the roller handle to a laminating position.
4. Press the **Run** button.
5. Once the threading card has exited the laminator, press the **STOP** button.
6. If you are not running the laminator, set the roller handle to the **RELEASE** position.
7. Now refer to the section entitled *Start Laminating*.

## TACKING NEW FILM TO EXISTING FILM

The following describes a method for loading film whereby the existing film present on the heat rollers may be used in place of the threading card to draw the new film through the laminator. The adhesive of the existing film must be tacky or liquefied. Leading edges of the new film will be overlapped onto the tacky adhesive of the old film. The existing film and the new film will be pulled through the laminator together. In Fig. 6-15, solid lines represent thermal films and dashed lines represent PSA films.

1. Cut remaining top and bottom film webs between the idler bar and heat rollers.

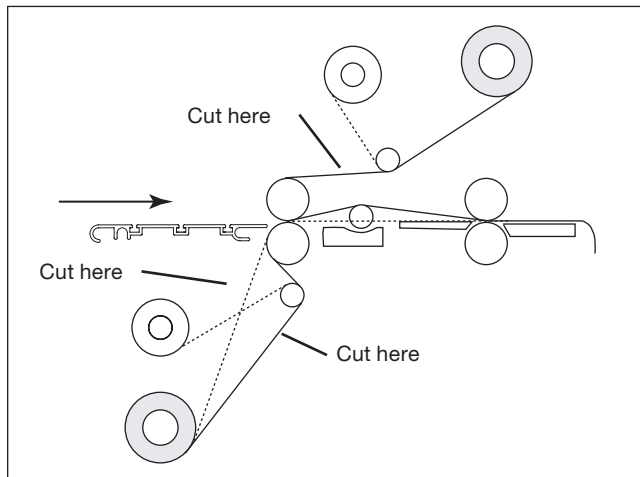

Fig. 6-15. Cutting Existing Films Prior to Re-loading.

**CAUTION:** Do not cut the heat rollers when cutting the film web

2. Remove the safety shield and tilt the feed table down.
3. Do not allow the adhesive side of the film to contact the heat or pull rollers. Liquefied or tacky adhesive deposited on heat rollers will require the rollers to be cleaned per the chapter entitled *Operator Maintenance*.
4. Replace both the top and bottom rolls of film with new rolls. Ensure the adhesive side is facing out.
5. Pull the film around the idler bars, with the exception of PSA mounting adhesives without a release liner.

6. Tack the new film to the existing film on the heat rollers. For PSA film, attach the release liner to the rewind tube.

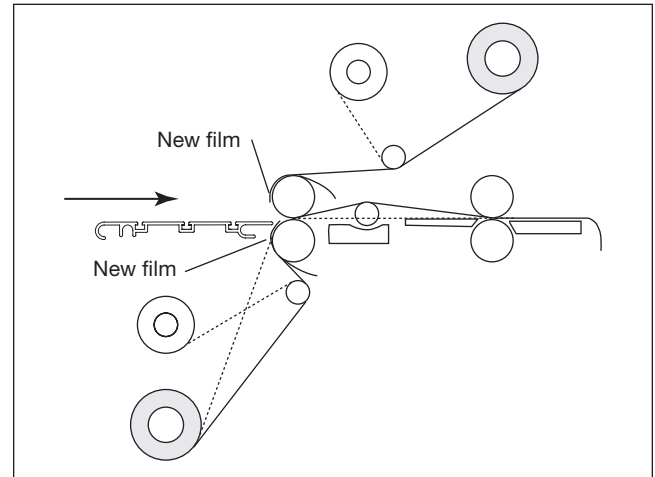

Fig. 6-16. Tacking New Film to Existing Film.

7. Replace the safety shield and feed table.
8. Use the foot switch to advance the film into the heat roller nip.
9. Observe the film being pulled through the laminator to assure that the remaining existing film and the new film are advancing concurrently. Any separation between the films will require stopping the motor immediately and the situation corrected.
10. Press **Stop** once the newly threaded film has completely exited the pull rollers.

## To UNWEB THE LAMINATOR

Unweb the laminator if you are changing film widths, cleaning the rollers, or have finished using the machine for the day.

1. Set the roller handle to the **Release** position.
2. Remove the safety shield and tilt the feed table down.
3. Cut remaining top and bottom film webs between supply rolls and heat rollers. **Be careful not to cut any of the rollers!**

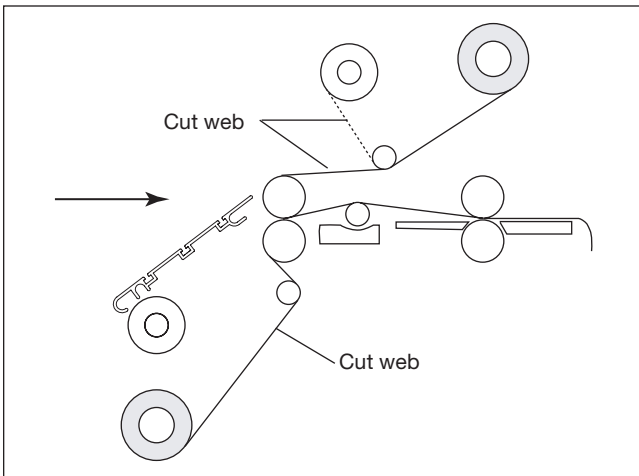

Fig. 6-17. Unwebbing the Laminator.

4. Carefully grab hold of the web (top and bottom film), from the back operating position and pull towards you. Do not allow the adhesive side of the film to contact the heat or pull rollers.

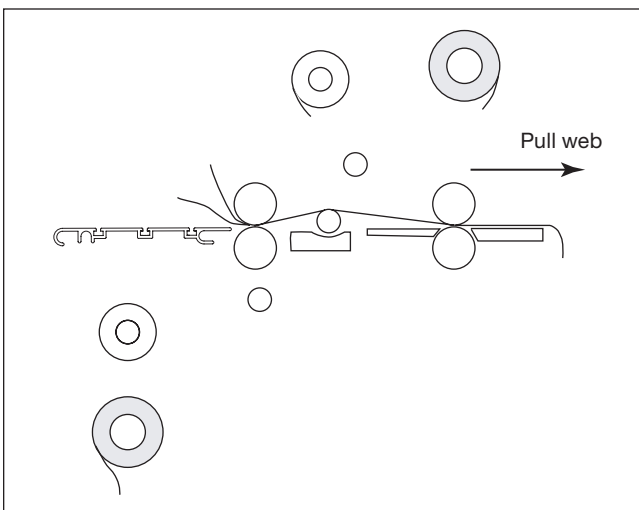

Fig. 6-18. Pulling Film Out of the Laminator.

## CLEARING A FILM JAM (WRAP-UP)

Film jams (wrap-ups) may occur if the film is loaded backwards or if the area at which film exits the equipment is blocked. The film, when jammed, wraps around the rollers. Jams also occur if something is too large to pass through the rollers.

Determine the best course of action to clear the jam. It may be necessary to rotate the rollers in the reverse direction. Set the speed to **1**. Press and hold the **Reverse** button on the control panel.

**CAUTION:** Be careful to not cut the pressure rollers when cutting the film. Failure to observe this notice can result in damage to the rollers.

1. Immediately press the **STOP** button to stop the machine.
2. Remove the safety shield and feed tray.
3. Do one of the following.
  - a. Pull one of the webs while running the laminator in reverse.
  - b. Cut the film near the rollers, set the pressure adjustment to **Release**, and pull the film out the back of the machine.
  - c. Cut the film near the rollers, set the pressure adjustment to **Release**, grasp the loose ends of the web, and pull straight out the front of the machine.
4. Replace the safety shield and feed tray.
5. Re-load the film if necessary. See the *Loading Film* section in this chapter.

## APPLICATIONS

### TIPS FOR PRE-COATING BOARDS

- Load the laminator as shown.

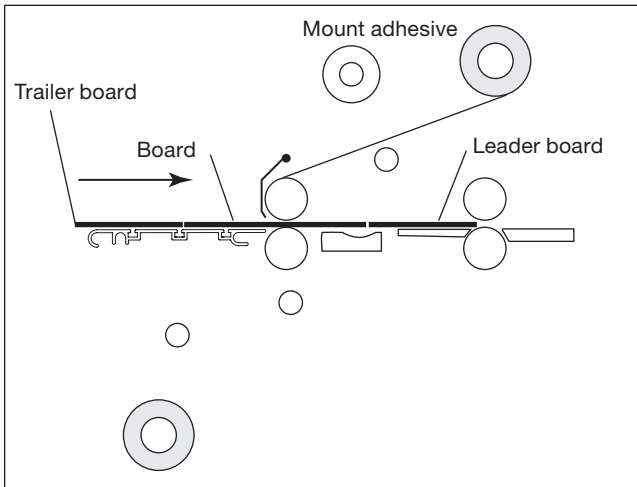

Fig. 6-19. Pre-coating Boards With Mount Adhesive.

- Remove the chill idler.
- Set the roller pressure handle to the correct thickness.
- The width of the roll should not exceed the width of the board by more than ½ in. (1.3 cm).
- Use a leader board to start the run and a trailer board to finish the run.
- Using the pull rollers will allow you to leave gaps between boards.
- If not using the pull rollers, have the boards nearby to butt end to end during feeding.

### TIPS FOR USING THE REAR ROLLERS

If the front rollers are heated, you may perform certain applications from the rear operating position of the laminator. You may perform mounting applications, pre-coating applications, and single side applications from the rear of the machine.

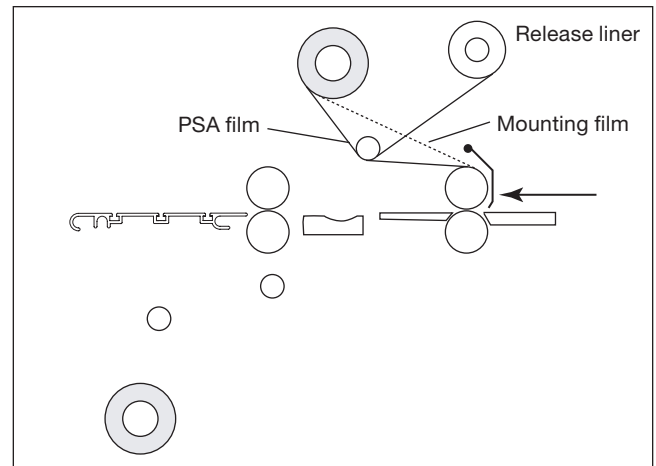

Fig. 6-20. Running From the Rear.

- Remove the chill idler if using boards.
- **Ensure the safety shield is located in the rear position and latched or use the foot switch for slow speed operation.**
- Ensure the **REAR CONTROLS** have been enabled.
- Use the foot switch to run the laminator.

**TIPS FOR MOUNTING ON PRE-COATED BOARDS**

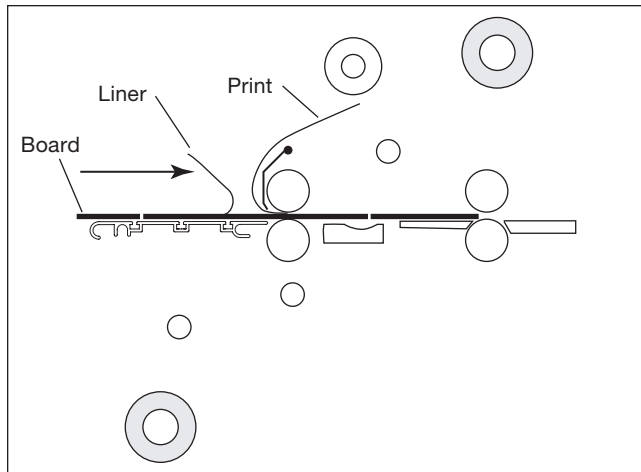

Fig. 6-21. Mounting a Print on a Board.

- Load the laminator as illustrated as shown.
- Heat at 125 °F (52 °C), may assist the process and increase output quality.
- Do not stop once you have started the mounting process through the machine.

**TIPS FOR PSA ENCAPSULATION**

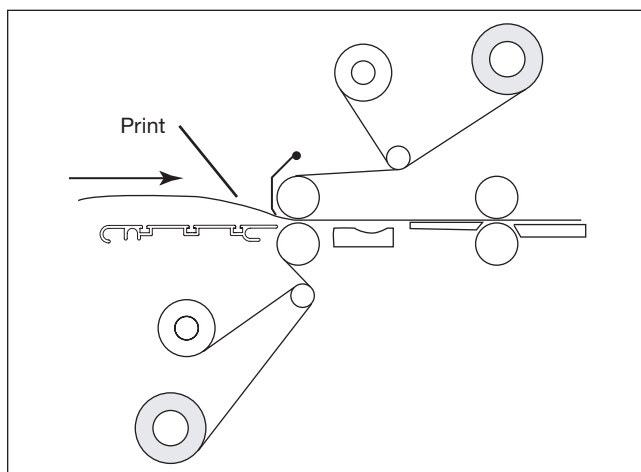

Fig. 6-22. PSA Encapsulation With Poly-in Film.

- Load the laminator as shown.
- Always use two rolls of the same width.
- Use minimal brake tension to achieve flat output.

- The separation of the laminate and the release liner should be maintained close to the heat rollers.
- A little heat, 125 °F (52 °C), may help eliminate silvering effects associated with PSA films.
- Use of the chill idler may or may not help in the output quality. Try both methods.

**TIPS FOR THERMAL ENCAPSULATION**

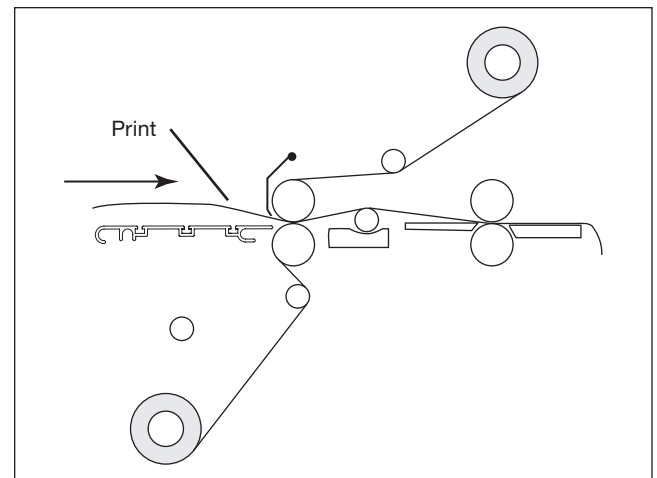

Fig. 6-23. Thermal Encapsulation With Poly-in Film.

- Load the laminator as shown for poly-in film.
- Always use two rolls of film the same width.
- Use minimal brake tension to achieve flat output.
- Increase speed gradually to maintain the activating temperature required for the laminate you are using.
- Length and width of image, ink coverage and paper type may effect the temperature and speed required.

## TIPS FOR ACCUSHIELD

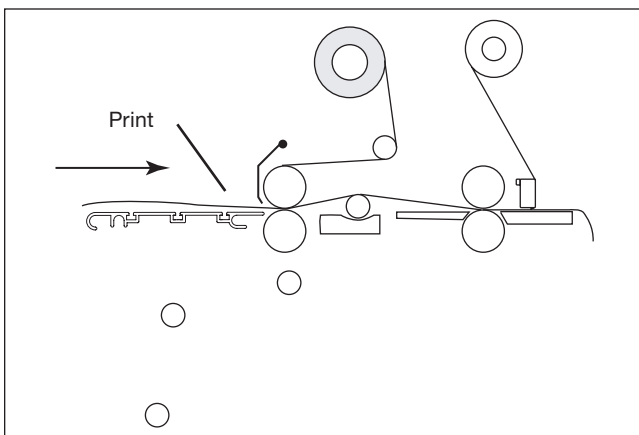

Fig. 6-24. Applying AccuShield.

- Load the laminator as shown.
- You must have the separator bar option to accurately run this material.
- Liner rewind tension will be greater than normal operating standards.
- Do not attempt to run this material greater than a speed setting of 4.

## LAMINATION GUIDE

### BASIC RULES

Do not attempt to laminate abrasive or metal objects such as staples, paper clips and glitter, as they may damage the rollers.

Do not force items into the nip area of the rollers. An item that is not easily drawn into the laminator by the rollers is probably too thick to laminate.

Wrinkles may result if an attempt is made to reposition an item once it has been grasped by the rollers.

Do not stop the laminator before an item has completely exited the pull rollers. Even a momentary stop may cause a mark on the laminated item.

Good, consistent lamination is a result of combining proper tension, heat, and dwell time. Dwell time is controlled by the speed of the motor and is defined as the amount of time the material to be laminated is compressed between the rollers.

As a general rule, thicker items and film need to run at slower speeds. Setting the speed control at slower settings gives the laminator longer dwell time thus allowing proper lamination of thick items. Thinner items, such as standard copier paper (20 lb. bond) and tissue paper can be run at faster speeds.

Do not combine thick and thin items at the same time, as this will result in a poor edge seal around the thinner material. If you are unsure that the laminator is set at the proper speed for the item to be laminated, run a test piece (scrap) of the same or similar material through the laminator. Make speed adjustments if necessary.

This manual provides general guidelines and is only a general reference guide. Different settings may be suitable as the lamination time and materials change.

**Important:** Test materials before running good materials through the laminator.



## FILM TENSION

Proper film tension, known as brake tension, is the minimum amount required to eliminate wrinkles in the finished item. The film should be taut. A properly adjusted roll of film should not require excessive force to turn by hand.

Film tension should be enough to introduce a minor amount of drag as the film unrolls. Insufficient tension causes wrinkles, while too much tension causes stretching (necking). Uneven tension between the top and bottom rolls creates curl. Too much upper tension creates upward curl while too much bottom tension causes downward curl.

The heat roller clutch is set at the factory. Periodic adjustments may be necessary if after adjusting unwind and rewind brake tensions do not improve your output quality.

## HEAT

The **WAIT (Too COLD)** indicator may appear if the speed is set too fast for the material being laminated. Either lower the speed setting or press **Stop** and wait until the **READY** indicator appears.

Operation of the laminator for more than thirty minutes at a time may necessitate a lower speed setting. It is recommended that, during periods of long runs, the items being laminated are alternated between thick and thin. Do not combine thick and thin items at the same time, as this will result in a poor edge seal around the thinner material. If you are unsure that the laminator is set at the proper speed for the item to be laminated, run a test piece (scrap) of the same or similar material through the laminator. This procedure is recommended because rotating the heat roller prior to lamination will more evenly distribute the heat. Make speed adjustments if necessary.

## OUTPUT

### 1. "D" waves in the image (Fig. 6-25 A).

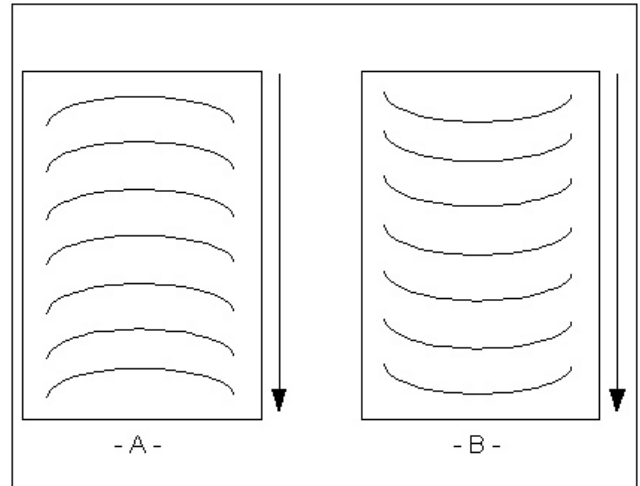

Fig. 6-25. "D" Waves In Image.

- Check paper tension.
- Paper may be damp or not dry.

### 2. "D" waves in the laminate (Fig. 6-25 B).

- Change roller handle pressure.

### 3. Straight waves in output (Fig. 6-26 A).

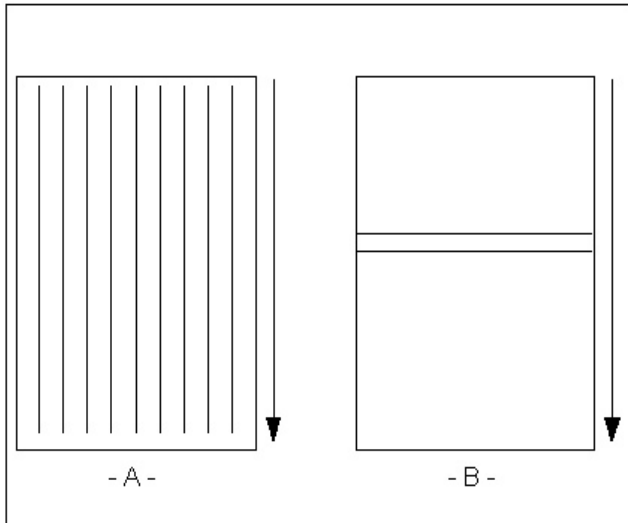

Fig. 6-26. Straight Waves in Output.

- Check operational settings for materials being used.
  - Insufficient cooling time.
  - Output was handled prior to cooling.
  - Use cooling feature if not on.
- ### 4. Indent waves in output after pull rollers (Fig. 6-26 B).
- Machine was stopped on print.

### 5. Angled waves in the output (Fig. 6-27 A & B).

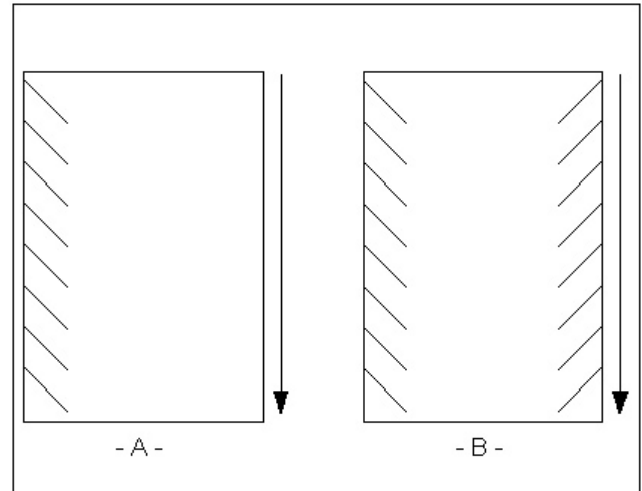

Fig. 6-27. Angled Waves in Output.

- Change roller handle pressure.
- Check for even paper tension (Fig. 6-27 A only).

## 7. OPERATOR MAINTENANCE

---

### MAINTAINING THE 62FM LAMINATOR

The only maintenance required by the operator is to periodically clean the rollers. The following procedure will help keep them free of dirt and adhesive, which has been deposited along the edge of the laminating film. Proper alignment of the rolls of film reduces the amount of adhesive on the rollers. Perform only the routine maintenance procedures referred to in these instructions.



**WARNING:** Do not attempt to service or repair the laminator. Failure to observe this warning could result severe personal injury or death or damage the machine.

### CLEANING THE ROLLERS

Keeping the rollers clean ensures that your finished items will not be damaged by dirt and adhesives. You will need a 3M™ Scotch-Brite™ pad and a clean rag moistened with water and dish soap.

- Never clean rollers with abrasive, sharp, or pointed objects.
- Do not use any other cleaning agents other than those listed above.
- Accumulated adhesive deposits on the rollers can cause damage to the rollers. Rotate the rollers at the lowest speed setting on the control panel.



**WARNING:** Hot surfaces and pinch points. Keep fingers and hands away from the heat pressure and pull rollers when the laminator is running. Failure to adhere to this warning could result in serious personal injury.

1. Remove the safety shield and feed table.
2. Remove the film from the laminator.  
Refer to *Loading Film* in the *Operation* chapter.
3. Preheat the laminator until the **READY** indicator appears
4. Gently rub the heat and pull rollers, and idlers with a 3M Scotch-Brite pad.  
**DO NOT USE METAL SCOURING PADS!** Do not use any abrasives to clean the rollers.
5. Use the dampened rag to remove any dust, dirt, and other foreign materials from the rollers.
6. Use the foot switch to rotate the rollers to an unclean portion.  
Keep your hands, fingers, and the rag away while running the machine. Be sure to remove any dust, dirt, and other foreign materials from the rollers.
7. Install the feed table and safety shield.

## TROUBLESHOOTING

SYMPTOM	POSSIBLE CAUSE	CORRECTIVE ACTION
The control panel display does not illuminate when <b>POWER I/O</b> is in the <b>ON</b> , marked "I", position.	Laminator not connected to electrical supply.	Insert attachment plug into receptacle.
Heat rollers do not turn when I press the <b>Run</b> button.	Safety shield is not properly installed.	Remove safety shield and properly replace it.
	Feed table not properly installed	Tilt feed table and properly replace it.
	Emergency Stop is engaged	Pull out on the emergency stop push button.
Heat rollers only turn if I use the foot switch.	Laminator is in foot switch mode.	Disengage the foot switch mode.
Rear controls do not operate.	Rear controls are not enabled.	Enable rear controls.
	Safety shield is not installed in rear position.	Install the safety shield.
Laminated items exhibit curling.	Tension between the top and bottom film roll is unequal.	Adjust film tension.
	Tension on top or bottom roll of film is too film loose.	Adjust film tension.
	Bottom film roll may be improperly loaded.	Make sure bottom roll of film is around idler bar and the it is in the normal operating position.
Adhesive deposited on heat rollers.	Top and bottom film webs not aligned.	Release heat and pull roller pressure, align the rolls of film.
	Laminate improperly loaded.	Adhesive (matte) side of laminate film may be against the heat rollers. Unweb and reload the film properly.

SYMPTOM	POSSIBLE CAUSE	CORRECTIVE ACTION
<p>Unsatisfactory adhesion of laminate.</p>	<p>Speed setting too fast for type of material being laminated.</p>	<p>Lower speed setting by pressing <b>Slow</b> button to slower speed</p>
	<p>Insufficient heat.</p>	<p>Wait for <b>READY</b> indicator to appear in the control panel display.</p>
	<p>Laminate improperly loaded.</p>	<p>Adhesive side of film must be facing away from the heat rollers. Bottom roll of film not threaded behind the idle bar.</p>
	<p>Heat rollers require cleaning.</p>	<p>Clean heat rollers per procedure in section <i>Maintaining the 62FM Laminator</i>.</p>
	<p>Laminated item unsuitable for adhesion.</p>	<p>Item may be dirty or may have nonporous surface that is extremely difficult to laminate.</p>
<p>Waves in my output</p>	<p>See sub section <i>Output</i>.</p>	<p>Under section titled <i>Lamination Guide</i>.</p>
	<p>Nips may be out of calibration.</p>	<p>Place a service call for calibration check.</p>





